

POWERMATIC[®]

WMH | **TOOL GROUP**

Operating Instructions and Parts Manual **Horizontal Panel Saw** Model HPS67



WMH TOOL GROUP

2420 Vantage Drive
Elgin, Illinois 60124
Ph.: 800-274-6848
www.wmhtoolgroup.com

Part No. M-0460273
Revision C1 11/06
Copyright © WMH Tool Group

Warranty and Service



WMH Tool Group, Inc., warrants every product it sells. If one of our tools needs service or repair, one of our Authorized Service Centers located throughout the United States can give you quick service. In most cases, any of these WMH Tool Group Authorized Service Centers can authorize warranty repair, assist you in obtaining parts, or perform routine maintenance and major repair on your POWERMATIC® tools. For the name of an Authorized Service Center in your area call 1-800-274-6848.

MORE INFORMATION

WMH Tool Group is consistently adding new products to the line. For complete, up-to-date product information, check with your local WMH Tool Group distributor, or visit powermatic.com.

WARRANTY

POWERMATIC products carry a limited warranty which varies in duration based upon the product.

 1 YEAR WARRANTY	Industrial Products	 5 YEAR WARRANTY	Non-Industrial Products
	Horizontal Panel Saws		Tablesaws
	Cut Off Saws		Vertical Panel Saws
	Rip Saws		Bandsaws
	Bandsaws		Jointers
	Jointers		Planers
	Planers		Planer/Molder
	Oscillating Edge Sanders		Dust Collection
	Belt Sanders		Disc Sanders
	Shapers		Edge Sanders
	Power Feeders		Drum Sanders
	Mortisers		Shapers
	Dovetailers		Drill Press's
			Mortisers
			Dovetailers

Warranty reverts to 1 Year if above products are used for commercial, industrial or educational purposes

WHAT IS COVERED?

This warranty covers any defects in workmanship or materials subject to the exceptions stated below. Cutting tools, abrasives and other consumables are excluded from warranty coverage.

WHO IS COVERED?

This warranty covers only the initial purchaser of the product.

WHAT IS THE PERIOD OF COVERAGE?

The general POWERMATIC warranty lasts for the time period specified in the product literature of each product.

WHAT IS NOT COVERED?

The Five Year Warranty does not cover products used for commercial, industrial or educational purposes. Products with a Five Year Warranty that are used for commercial, industrial or education purposes revert to a One Year Warranty. This warranty does not cover defects due directly or indirectly to misuse, abuse, negligence or accidents, normal wear-and-tear, improper repair or alterations, or lack of maintenance.

HOW TO GET SERVICE

The product or part must be returned for examination, postage prepaid, to a location designated by us. For the name of the location nearest you, please call 1-800-274-6848.

You must provide proof of initial purchase date and an explanation of the complaint must accompany the merchandise. If our inspection discloses a defect, we will repair or replace the product, or refund the purchase price, at our option.

We will return the repaired product or replacement at our expense unless it is determined by us that there is no defect, or that the defect resulted from causes not within the scope of our warranty in which case we will, at your direction, dispose of or return the product. In the event you choose to have the product returned, you will be responsible for the handling and shipping costs of the return.

HOW STATE LAW APPLIES

This warranty gives you specific legal rights; you may also have other rights which vary from state to state.

LIMITATIONS ON THIS WARRANTY

WMH TOOL GROUP LIMITS ALL IMPLIED WARRANTIES TO THE PERIOD OF THE LIMITED WARRANTY FOR EACH PRODUCT. EXCEPT AS STATED HEREIN, ANY IMPLIED WARRANTIES OR MERCHANTABILITY AND FITNESS ARE EXCLUDED. SOME STATES DO NOT ALLOW LIMITATIONS ON HOW LONG THE IMPLIED WARRANTY LASTS, SO THE ABOVE LIMITATION MAY NOT APPLY TO YOU.

WMH TOOL GROUP SHALL IN NO EVENT BE LIABLE FOR DEATH, INJURIES TO PERSONS OR PROPERTY, OR FOR INCIDENTAL, CONTINGENT, SPECIAL, OR CONSEQUENTIAL DAMAGES ARISING FROM THE USE OF OUR PRODUCTS. SOME STATES DO NOT ALLOW THE EXCLUSION OR LIMITATION OF INCIDENTAL OR CONSEQUENTIAL DAMAGES, SO THE ABOVE LIMITATION OR EXCLUSION MAY NOT APPLY TO YOU.

WMH Tool Group sells through distributors only. The specifications in WMH catalogs are given as general information and are not binding. Members of WMH Tool Group reserve the right to effect at any time, without prior notice, those alterations to parts, fittings, and accessory equipment which they may deem necessary for any reason whatsoever.

Table of Contents

Warranty and Service	2
Table of Contents	3
Warning.....	4
Introduction	6
Specifications	6
Machine Dimensions	7
Unpacking	8
Installation and Assembly	8
Installing Extension Tables.....	9
Installing Crosscut Table	9
Installing Crosscut Fence	9
Installing Guide Bar.....	10
Installing Rip Fence.....	10
Installing Over Arm.....	10
Installing Blade Guard.....	10
Installing Miter Fence.....	11
Electrical Connections.....	11
Installing/Replacing Main Blade.....	11
Installing/Replacing Scoring Blade	12
Riving Knife.....	12
Starting the Machine	13
Dust Collection.....	13
Adjustments	14
Sliding Table Parallel to Blade.....	14
Setting Scoring Blade.....	14
Setting Blade Guard.....	14
Sliding Table Lock.....	15
Crosscut Fence.....	15
Miter Fence.....	17
Rip Fence	17
Rip Fence Scale Calibration	17
Tensioning the Belt	18
Precision Tuning Your Panel Saw.....	18
Free Cut (Blade to Sliding Table)	19
Free Cut (Blade to Rip Fence).....	20
Square Cut	21
Scoring Blade	21
Operation	21
Maintenance.....	22
Optional Accessories	24
Replacement Parts	24
Parts List: Motor and Arbor Assembly.....	25
Motor and Arbor Assembly.....	27
Parts List: Scoring Motor and Arbor Assembly.....	28
Parts List: Stand and Table Assembly	30
Parts List: Support Arm Assembly	32
Support Arm Assembly.....	33
Parts List: Cross Cut Fence Assembly.....	34
Cross Cut Fence Assembly.....	35
Parts List: Rip Fence Assembly.....	36
Rip Fence Assembly	37
Parts List: Over Arm Guard Assembly	38
Over Arm Guard Assembly.....	39
Parts List: Sliding Table Assembly.....	40
Sliding Table Assembly.....	42
Parts List: Electrical Components – 3 Phase	43
Parts List: Electrical Components – 1 Phase	43
Electrical Connections – 3 Phase.....	44
Electrical Connections – 1 Phase.....	45

Warnings

As with all machines, there is a certain amount of hazard involved with the use of this panel saw. Use the machine with the respect and caution demanded where safety precautions are concerned. When normal safety precautions are overlooked or ignored, personal injury to the operator can result.

1. Read and understand the entire owner's manual before attempting assembly or operation. Know the limitations and hazards associated with this machine.
2. Read and understand the warnings posted on the machine and in this manual. Failure to comply with all of these warnings may cause serious injury.
3. Replace the warning labels if they become obscured or removed.
4. This panel saw is designed and intended for use by properly trained and experienced personnel only. If you are not familiar with the proper and safe operation of a panel saw, do not use until proper training and knowledge have been obtained.
5. Do not use this panel saw for other than its intended use. If used for other purposes, WMH Tool Group disclaims any real or implied warranty and holds itself harmless from any injury that may result from that use.
6. Always wear approved safety glasses/face shields while using this panel saw. Everyday eyeglasses only have impact resistant lenses; they are not safety glasses.
7. Before operating this panel saw, remove tie, rings, watches and other jewelry, and roll sleeves up past the elbows. Remove all loose clothing and confine long hair. Protective type footwear should be used. Anti-skid floor strips are recommended. Do **not** wear gloves.
8. Where the noise exceeds the level of exposure allowed in Section 1910.95 of the OSHA Regulations, use hearing protective devices.
9. Some dust created by power sanding, sawing, grinding, drilling and other construction activities contain chemicals known to cause cancer, birth defects or other reproductive harm. Some examples of these chemicals are:
 - Lead from lead based paint.
 - Crystalline silica from bricks, cement and other masonry products.
 - Arsenic and chromium from chemically treated lumber.Your risk of exposure varies, depending on how often you do this type of work. To reduce your exposure to these chemicals, work in a well-ventilated area and work with approved safety equipment, such as face or dust masks that are specifically designed to filter out microscopic particles.
10. Do not operate this machine while tired or under the influence of drugs, alcohol or any medication.
11. Make certain the switch is in the **OFF** position before connecting the machine to the power supply.
12. Make certain that the machine frame is electrically grounded and that a ground lead is included in the incoming electrical service. In cases where a cord and plug are used, make certain that the grounding plug connects to a suitable ground. Follow the grounding procedure indicated in the National Electrical Code.
13. Disconnect machine from power source before performing any service or maintenance or when changing blades. A machine under repair should be RED TAGGED to show it should not be used until the maintenance is complete.
14. Remove adjusting keys, wrenches, scrap or cleaning rags. Form a habit of checking to see that all such items are removed from the machine before turning it on.
15. Keep safety guards in place at all times when the machine is in use. If removed for maintenance purposes, use extreme caution and replace the guards before operating the machine.
16. Provide for adequate space surrounding work area and non-glare, overhead lighting.



Warnings

17. Check damaged parts. Before further use of the machine, a guard or other part that is damaged should be carefully checked to determine that it will operate properly and perform its intended function. Check for alignment of moving parts, binding of moving parts, breakage of parts, mounting and any other conditions that may affect its operation. A guard or other part that is damaged should be properly repaired or replaced.
18. Keep the floor around the machine clean and free of scrap material, saw dust, oil and other liquids to minimize the danger of tripping or slipping. Be sure the table is free of all scrap, foreign material and tools before starting to cut.
19. Make certain the work area is well lighted and that a proper exhaust system is used to minimize dust. Anti-skid floor strips are recommended on the floor area where the operator normally stands and each machine's work area should be marked off. Provide adequate work space around the machine.
20. Keep visitors a safe distance from the work area. **Keep children away.**
21. Make your workshop child proof with padlocks, master switches or by removing starter keys.
22. Give your work undivided attention. Looking around, carrying on a conversation and "horse-play" are careless acts that can result in serious injury.
23. Maintain a balanced stance and keep your body under control at all times. Do not overreach or use excessive force to perform any machine operation. Do not stand in line with the saw blade or work piece and do not allow anyone else to do so.
24. Use the right tool at the correct speed and feed rate. Do not force a tool or attachment to do a job for which it was not designed. The right tool will do the job better and safer.
25. Maintain tools in top condition. Check the saw blade for cracks or missing teeth. Do not use a cracked or dull blade or one with missing teeth or improper set. Make sure the blade is securely locked on the arbor.
26. Turn off the machine before cleaning.
27. Do not stand on the machine. Serious injury could occur if the machine tips over.
28. Never leave the machine running unattended. Turn the power off and do not leave the machine until it comes to a complete stop.
29. Remove loose items and unnecessary work pieces from the area before starting the machine.
30. Keep hands clear of the blade area. Do not reach past the blade to clear parts or scrap with the saw blade running. Never saw free hand. Avoid awkward operations and hand positions where a sudden slip could cause your hand to contact the blade.
31. Saw blade rotation: Be sure the main saw blade rotates clockwise when viewed from the front (operator's side). The scoring blade should rotate counterclockwise when viewed from front.
32. Do not attempt to saw boards with loose knots or with nails or other foreign material, on its surface. Do not attempt to saw twisted, warped, bowed or "in wind" stock unless one edge has been jointed for guiding purposes prior to sawing.
33. If the operator leaves the machine area for any reason, he should turn "off" the power to the saw motor and wait until the saw blade comes to a complete stop before his departure. In addition, if the operation is complete, he should clean the saw and the work area. NEVER clean the saw with power "on" and never use the hands to clear sawdust and debris; use a brush or compressed air.
34. Use only Powermatic or factory authorized replacement parts and accessories; otherwise the warranty and guarantee is null and void.

Familiarize yourself with the following safety notices used in this manual:

CAUTION This means that if precautions are not heeded, it may result in minor injury and/or possible machine damage.

WARNING This means that if precautions are not heeded, it may result in serious injury or possibly even death.

Introduction

This manual is provided by WMH Tool Group covering the safe operation and maintenance procedures for a Powermatic Model HPS67 Horizontal Panel Saw. This manual contains instructions on installation, safety precautions, general operating procedures, maintenance instructions and parts breakdown. This machine has been designed and constructed to provide years of trouble free operation if used in accordance with instructions set forth in this manual. If there are any questions or comments, please contact either your local supplier or WMH Tool Group. WMH Tool Group can also be reached at our web site: www.wmhtoolgroup.com.

Specifications

Model number (3 Phase model).....	HPS67
Stock number (3 Phase model).....	1791287
Model number (1 Phase model).....	HPS67-1
Stock number (1 Phase model).....	1791286
Main motor (3 Phase model).....	TEFC, 5 HP, 3Ph, 230V
Main motor (1 Phase model).....	TEFC, 3HP, 1Ph, 230V
Blade speed	4500 RPM
Blade size.....	12" (315 mm)
Arbor size	30 mm
Dado size (width x bore).....	13/16" x 5/8"
Cutting depth.....	4" (100 mm)
Scoring motor.....	3/4 HP
Scoring blade size	100 to 120 mm
Scoring blade arbor	20 mm
Scoring blade speed	6500 RPM
Sliding table carriage width.....	13" (330 mm)
Sliding table carriage stroke.....	67" (1700 mm)
Rip capacity.....	50" (1270 mm)
Main and scoring blade tilt	90 to 45 degrees
Main table size cast iron	37" x 20" (940 x 508 mm)
Right side extension table.....	31" x 18" (790 x 460 mm)
Rear extension table size.....	30" x 20" (760 x 500 mm)
Working table height.....	34" (860 mm)
Crosscut table size	42" x 20" (1060 x 510 mm)
Crosscut fence size with extension	101" (2565 mm)
Mitre Fence length with flip stop, clamp.....	31" (790 mm)
Overall size	122" x 54" x 93" (3100 x 1370 x 2360 mm)
Dust collection ports (two).....	4" (100 mm)
Gross weight	1,100 lbs. (500 kg.)
Net weight	902 lbs. (410 kg.)

The above specifications were current at the time this manual was published, but because of our policy of continuous improvement, WMH Tool Group reserves the right to change specifications at any time and without prior notice, without incurring obligations.

Machine Dimensions

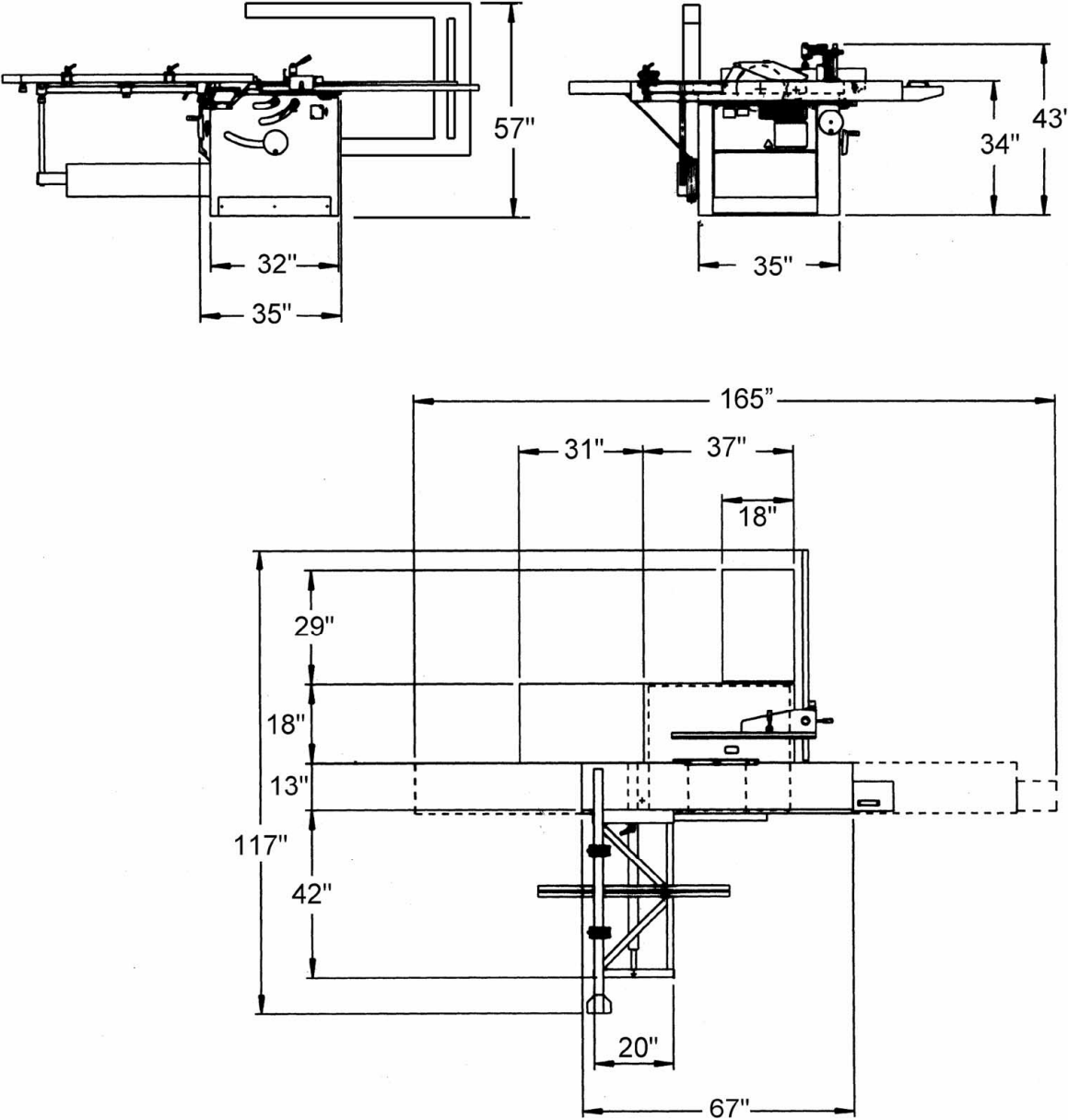

Figure 1

Unpacking

Remove crate from around machine and check for shipping damage and ensure all parts are intact. Report any damage immediately to your distributor and shipping agent. Read the instruction manual thoroughly for assembly, alignment, maintenance and safety instructions.

Contents of crate:

- 1 panel saw
- 1 over arm
- 1 upper guard
- 2 blade guards
- 1 steel pin
- 1 crosscut table
- 1 mitre fence
- 1 arbor wrench
- 1 set hex wrenches
- 1 open-end wrench
- 2 extension tables
- 1 extension table leg
- 1 hardware bag
- 1 instruction manual
- 1 warranty card

Installation and Assembly

(NOTE: Consult the parts breakdowns at the back of this manual if further clarification of assembly process is needed.)

1. Lift the machine off the pallet with crane or forklift, using a hoist. When the machine is sitting on the ground, it can be lifted by removing the side cover plate (Figure 2) and sliding forks through the two openings.
2. When the machine has been placed in the intended location, it must be leveled to ensure the smooth motion of the sliding table. Use a level on top the table, and adjust any of the four bolts in the corners of the base (Figure 3) as necessary.
3. The support arm and sliding table have both been locked for transportation. Release the support arm by lifting the lower lever (Figure 4). Release the sliding table by pushing in the upper lever (Figure 4).

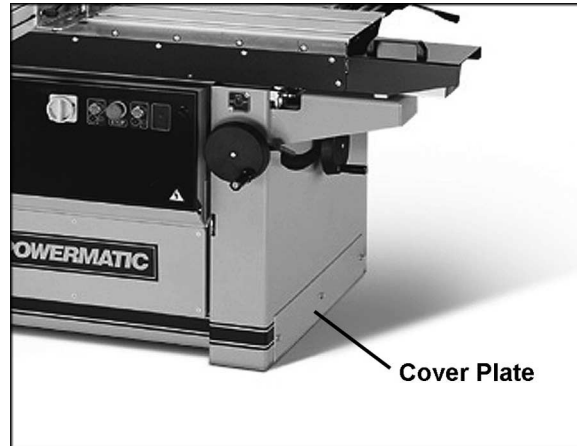

Figure 2

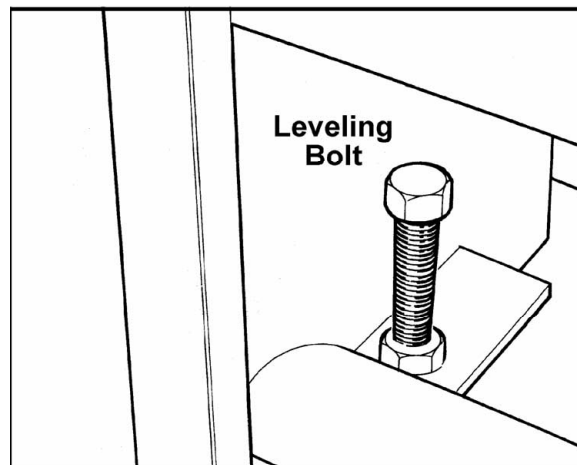

Figure 3

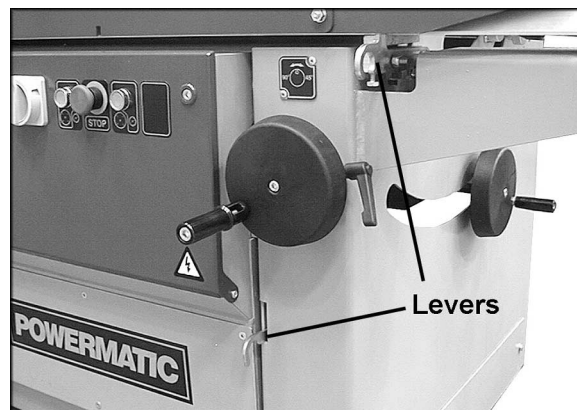

Figure 4

Installing Extension Tables

1. Mount the right extension tables to the edge of the cast iron table (Figure 5) with two M8 x 25 cap screws and two M8 flat washers. Do not tighten yet.
2. Level the extension table surface to that of the cast iron table, then firmly tighten screws.
3. Mount the left table extension (Figure 6) with two M8 x 20 cap screws and two M8 flat washers to the cast iron table. Then mount the top of the two braces (Figure 6) to the table with two M6 flat screws, flat washers and nuts. Mount the bottom of the braces to the stand with two M8 x 20 cap screws and two M8 lock washers. Do not tighten yet.
4. Level the extension table surface to the cast iron table, then firmly tighten all screws.
5. A leg assembly (Figure 6) is provided for the outer edge of the extension table as shown. The bottom end of the leg is adjustable for leveling.

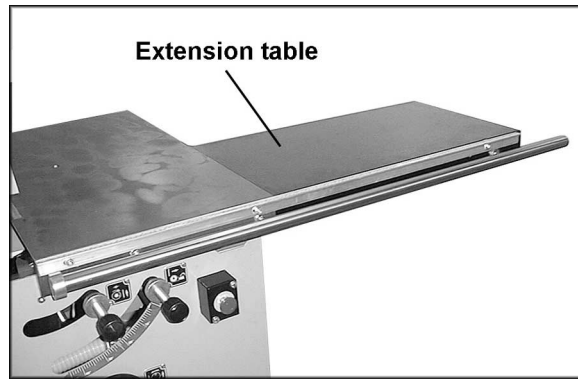

Figure 5

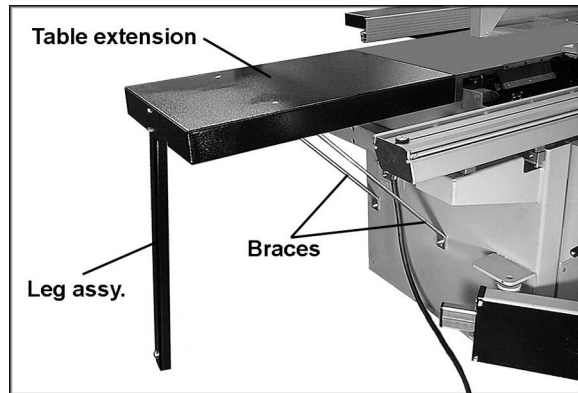

Figure 6

Installing Crosscut Table

1. Slide the crosscut table (Figure 7) onto the sliding table from the left end. The rod protruding up from the support arm should slip into the hole on the bottom of the crosscut table.
2. Position the two brackets (Figure 7) so that the crosscut table will easily ride along the flat bar on the front edge of the sliding table.
3. Tighten the lock lever to secure the table's position.

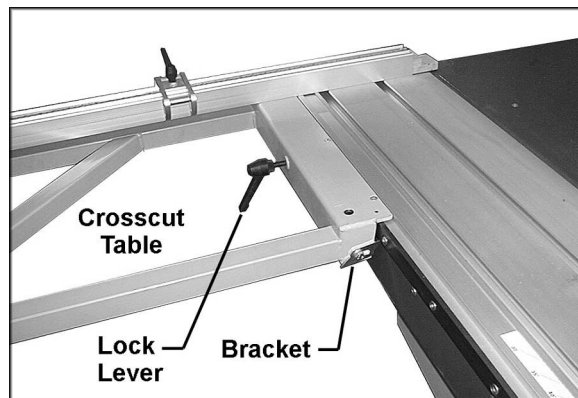

Figure 7

Installing Crosscut Fence

1. The crosscut table has four holes allowing the fence to be placed in two positions: at the left or right of the crosscut table. Figure 8 shows the fence in the left set of holes.
2. Place the crosscut fence on to the crosscut table and lock it in position with the knobs.
3. The cross tube is mounted to the crosscut table as shown, and secured by two knobs beneath.

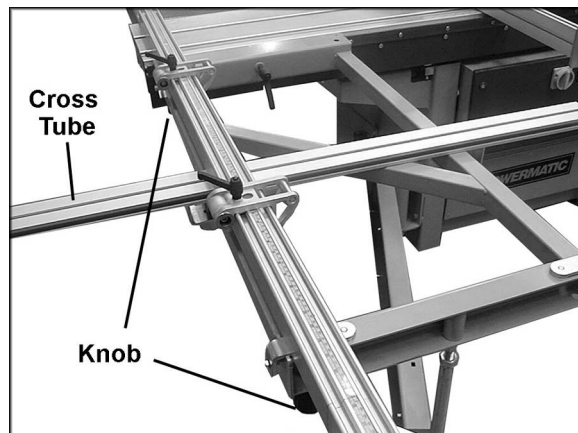

Figure 8

Installing Guide Bar

1. Mount the scale (Figure 9) to the edge of the cast iron table with three M8 x 30 socket head screws, M8 flat washers, and spacers.
2. Mount the cylindrical steel guide bar to the edge of the cast iron table, using the four M12 hex nuts and flat washers.
3. The outside edge of the bar along its entire length should be approximately 2-1/2" from the table, to allow for smooth movement of the fence.

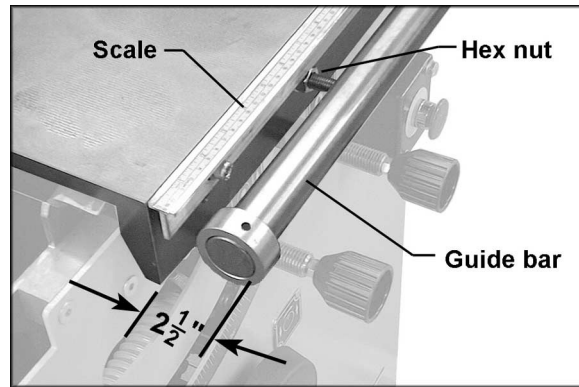

Figure 9

Installing Rip Fence

The rip fence assembly (Figure 10) has a cast iron body with a sliding aluminum fence. Mount the body by sliding it onto the end of the guide bar while lifting the handle. Loosen the fence lock and slide the aluminum fence onto the body as shown.

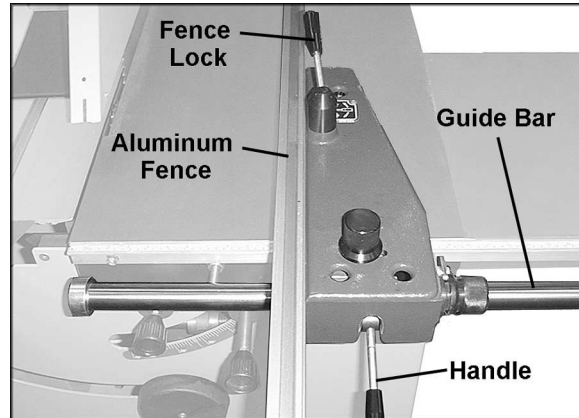

Figure 10

Installing Over Arm

Mount the over arm (Figure 11) with the four M10 x 30 socket head cap screws, four M10 flat washers and four M10 hex nuts to the holes on the side of the frame. Tighten the screws and nuts securely to the side of the frame.

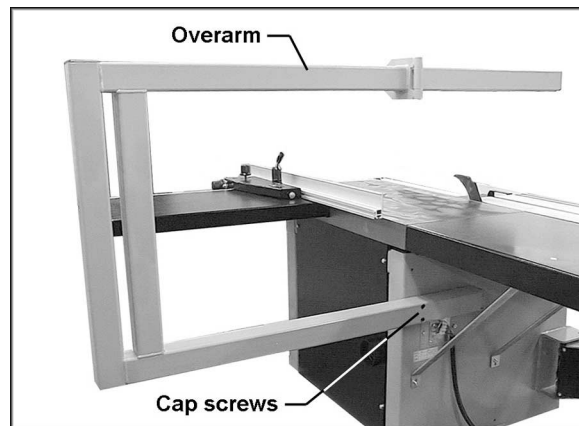

Figure 11

Installing Blade Guard

Mount the upper guard assembly (Figure 12) to the over arm with two M10x80 socket head cap screws, two M10 flat washers, and an M10 hex nut (A, Figure 12).

Install the blade guard using the bolt (B, Figure 12).

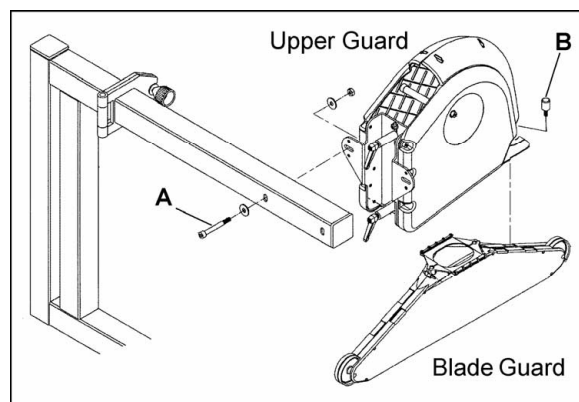

Figure 12

Installing Miter Fence

Mount the miter fence assembly as shown in Figure 13. Tighten the rod (A, Figure 13) with the provided pin into the stationary T-nut.

NOTE: Do not move the stationary T-nut; it has been calibrated with the angle scale.

Screw the large lock lever (B, Figure 13) down into the other T-nut.

Loosen the small lock levers and slide the aluminum fence (C, Figure 13) on to the assembly as shown. The adjustable stop can be mounted to the fence if desired for making multiple cuts of the same length.

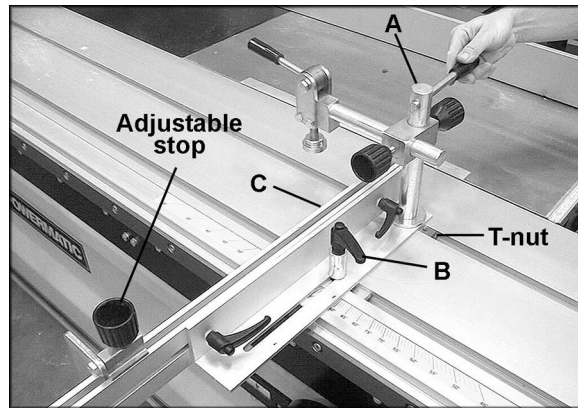

Figure 13

Electrical Connections

⚠WARNING Electrical connections must be performed by a qualified electrician. The machine must be properly grounded to help prevent electrical shock and possible death.

Check that the voltage of the machine corresponds with the voltage of your power supply.

Remove the electrical box cover and introduce the cable. Connect the three wires to the terminals L1, L2, L3 (Figure 14).

The green ground wire must be connected to the yellow wire terminal.

Turn on the main saw motor [see "Starting the Machine"] and check that the blade arbor rotates clockwise (as viewed from front of machine). If it does not, turn motor off, disconnect from power source, and exchange wires L1 and L2.

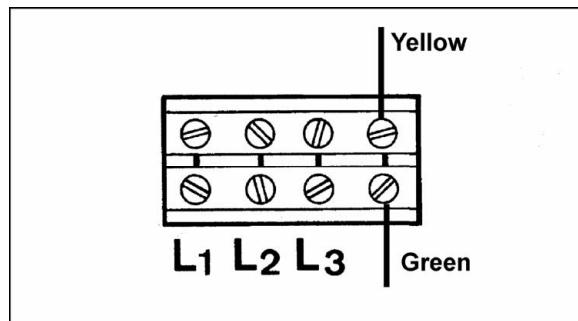

Figure 14

Installing/Replacing Main Blade

⚠CAUTION Use care when working around sharp blades. Use only carbide tipped saw blades, not High Speed Steel blades.

1. Disconnect machine from power source.
2. Push sliding table all the way to the left, and open blade cover.
3. Raise main saw blade to its highest position and place spanner (C, Figure 15) over the arbor nut (A, Figure 15).
4. Insert the locking pin (B, Figure 15) into the hole on the saw table and turn the arbor with the spanner until the locking pin engages the hole in the saw arbor pulley.

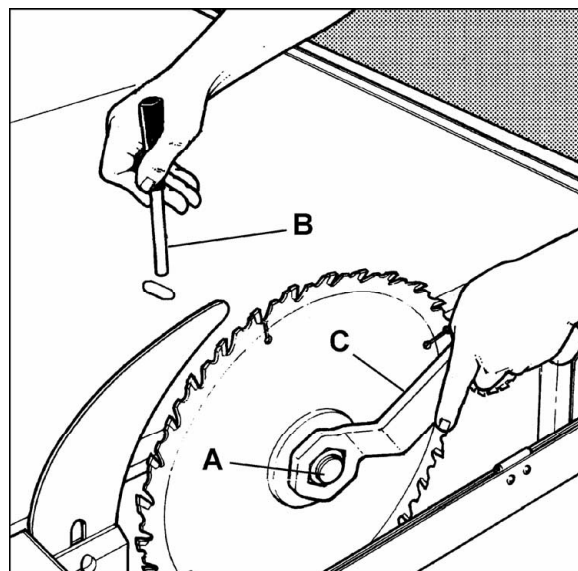

Figure 15

5. Unlock the nut (NOTE: Left hand threads – loosen by turning clockwise).
6. Make sure the set screws in the adaptor are set flush on the blade side. (They should protrude to the rear to engage the arbor for positive drive). See Figure 16. Clean the mating surfaces, install new blade, and tighten arbor nut securely.
7. Remove locking pin (B, Figure 15) and close blade cover.

SAFETY TIP: Tape a red rag on the locking pin and drape it over the blade while pin is inserted. This will remind you to remove the pin before starting the saw!

Installing/Replacing Scoring Blade

1. Disconnect machine from power source.
2. Push sliding table all the way to the left and open blade cover.
3. Tilt scoring blade all the way, and place spanner (A, Figure 17) on the flat of the arbor.
4. Loosen the bolt with the hex wrench (B, Figure 17). (NOTE: Right hand threads-turn counterclockwise to loosen).
5. Mount scoring blade and re-tighten bolt. Close blade cover.

Riving Knife

The machine is equipped with a riving knife (A, Figure 18) for use with saw blades up to 315mm in diameter.

The purpose of the riving knife (or "splitter") is to prevent the kerf from closing as it leaves the cutting teeth, and thereby reduce the chance of the kerf coming in contact with the up-running teeth of the blade and causing binding or a dangerous kickback. When the forward edge of the workpiece reaches the riving knife, the knife also helps guide the rest of the cut and will prevent the up-running teeth from scoring the workpiece.

The riving knife must be adjusted so that over its entire length the gap between saw blade and riving knife does not exceed 3 to 8mm.

The riving knife can be adjusted in both vertical and horizontal directions. The highest point of the riving knife should never exceed 3mm above the highest placed saw blade tooth.

Use the central bolt (B, Figure 18) and the three adjustment screws (C, Figure 18). After adjustment, always lock the central bolt (B, Figure 18).

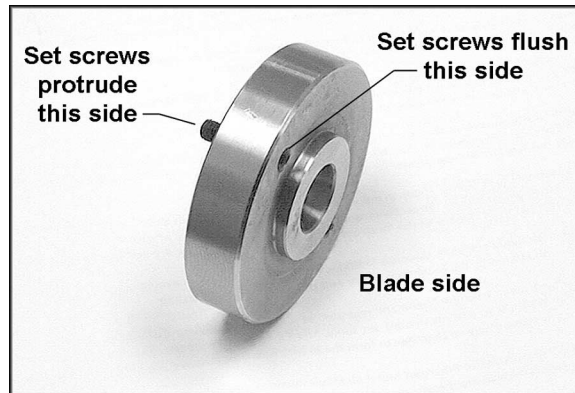

Figure 16

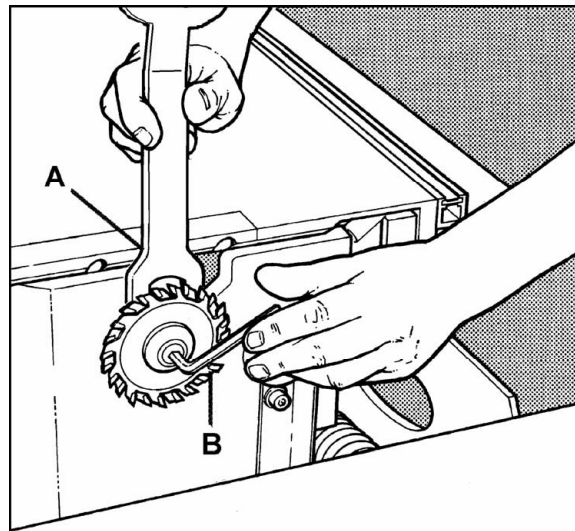

Figure 17

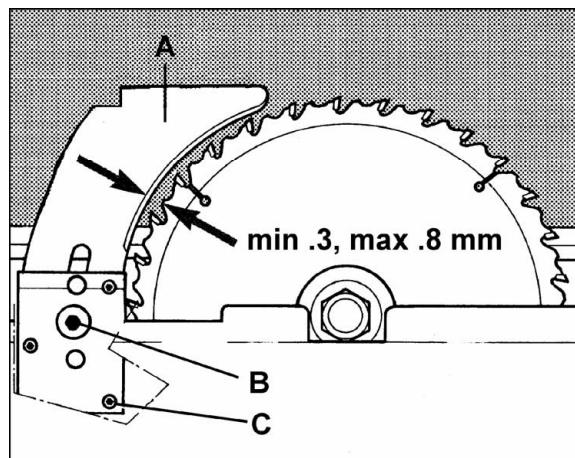

Figure 18

⚠WARNING Do not remove the riving knife for saw operations.

For slotting or grooving, the riving knife has to be adjusted in such a way that the upper part of the riving knife is never set lower than the highest sawtooth in use.

Starting the Machine

NOTE: The machine will not start if the blade cover or the rear door is open.

When starting in Star-Delta mode, proceed as follows (Figure 19):

- 1 – Turn Main Switch to position "I".
- 2 – Turn Star-Delta switch into star position "Y".
- 3 – Push Main Motor start button.
- 2 – After five seconds, put Star-Delta switch into delta position "Δ".

⚠CAUTION This five second delay is necessary for the motor to gain full speed before switching to delta. If you forget to switch to delta, the motor will operate at full speed but without power, and the motor may become damaged.

- 4 – Push Scoring Motor start button (main motor must be running).
- 5 – Emergency stop button halts both main and scoring motors.

The main motor is equipped with an automatic brake which stops the motor within 10 seconds after the machine is shut off.

Fuses are located inside the electrical control panel. The machine must be disconnected from power supply when opening this panel.

This machine has overload protection on both main and scoring motors. Should the motor be shut off by one of these protectors, wait a few minutes until the overload has cooled down before restarting.

Dust Collection

It is strongly recommended that a dust collection system be connected to the HPS67. The dust collector should have sufficient capacity for this size machine. Both the outlet on the blade guard and on the machine base should be connected to the dust collection system.

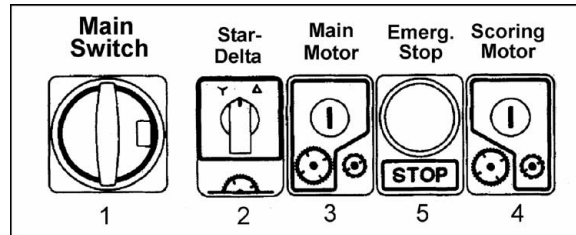

Figure 19

Adjustments

Sliding Table Parallel to Blade

The position of the sliding table relative to the machine is factory set, but should be checked periodically as the saw receives use. To ensure a clean cut, the sliding table must be set parallel to the saw blade. If adjustment is ever needed, proceed as follows:

1. The bolts (B, Figure 20) are used to adjust the height of the sliding table. They are pre-set at the factory.
2. Use bolts (A, Figure 20) to correct parallelism between sliding table and saw blade.

Setting Main Blade (Figures 21 and 22)

Adjust the height of the saw blade with the handwheel on the side of the machine. One turn of the handwheel raises or lowers the blade by 2.5mm.

The blade is tilted by using the front handwheel. The blade can be tilted at any angle between 90 and 45 degrees. After setting, lock the blade in this position with the lock lever. The blade angle can be read on the tilt scale.

NOTE: The 90 and 45 degree stops are pre-set at the factory and should require no adjustment. After setting the main blade at the desired cutting angle, the cutting depth of the scoring blade must be re-set.

Setting Scoring Blade

Turn the scoring blade height knob (Figure 22). One turn raises or lowers the scoring blade by 3 mm.

Each time the main saw blade is resharpened or replaced, the scoring blade must be adjusted laterally to match the main blade teeth. This must be done to ensure a clean cut free of splintering. Lateral movement is obtained by turning the lateral adjustment knob (Figure 22), then locking it at the desired setting.

Setting Blade Guard

The two handles (Figure 23) are for setting the guard height limits. Loosen a handle and slide the bracket as needed. Both handles on the guard should be tightened securely before operating the panel saw.

When the arbor is tilted for a bevel cut, mount the alternate lower guard with the convex back (Figure 23).

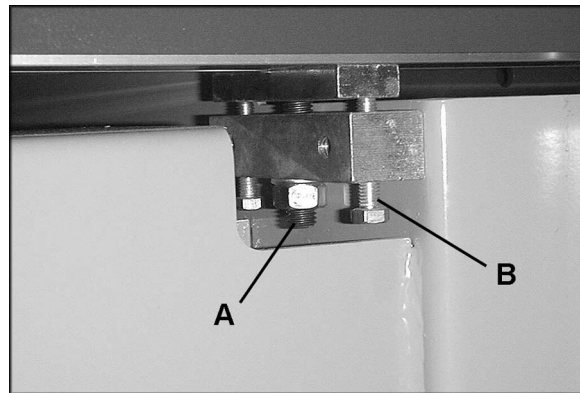

Figure 20

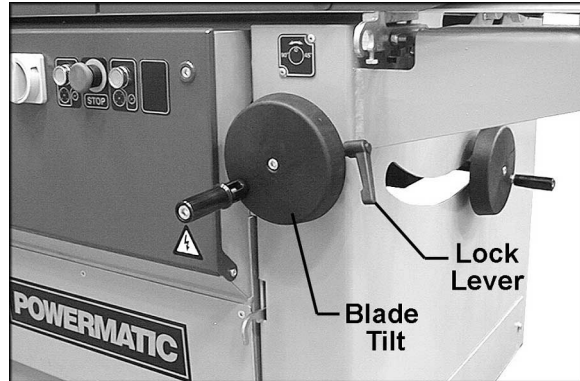

Figure 21

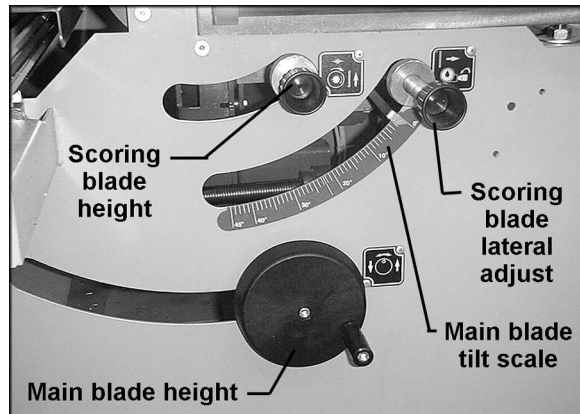

Figure 22

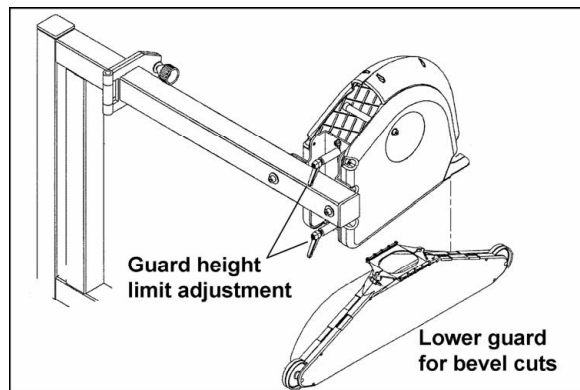

Figure 23

⚠WARNING When bevel cutting, make sure the appropriate blade guard has been mounted before operating the saw.

Sliding Table Lock

When loading panels and when cutting using the rip fence, the sliding table should be locked.

To lock the sliding table, pull lever (Figure 24) into one of the slots in the sliding table.

Over a long period of time, if many short movements of the sliding table are made (e.g. crosscutting solid wood) then it is possible that the ball carrier between the upper and lower part of the sliding table will move. This means it will no longer be correctly positioned to allow the sliding table to slide through its full course. The operator will feel resistance in the sliding table motion and the full stroke will not be achieved. This effect can be corrected simply by pushing the table with a few short, light pushes against the buffer stop at the end, until the position of the ball carrier is adjusted and the table can be moved again along its full stroke.

Crosscut Fence

The 90-degree angle of the fence is factory set. However, should adjustment ever be needed, proceed as follows:

1. Loosen the two bolts (A, Figure 25).
2. Turn bolt (B, Figure 25) to open or close the angle of the fence in relation to the saw blade.
3. Re-tighten bolts (A, Figure 25).

Before using the first time, and each time a new blade is installed, the scales must be calibrated. Proceed as follows:

1. Put the stop (Figure 26) at a certain measure and cut off a sample.
2. Measure the exact length of the sample. Loosen the screw (Figure 26) which holds the scale and move the scale until the measurement corresponds to the length of the previously cut sample. The main part of the fence is now calibrated to the saw blade.
3. The scale on the telescopic extension of the fence should now be checked and adjusted. Move the other stop to the outermost edge of the extension fence until the edge of the stop is flush with the edge of the fence (Figure 27). Lock the stop in position by tightening the handle.

NOTE: DO NOT loosen the stop until the adjustment procedure has been completed.

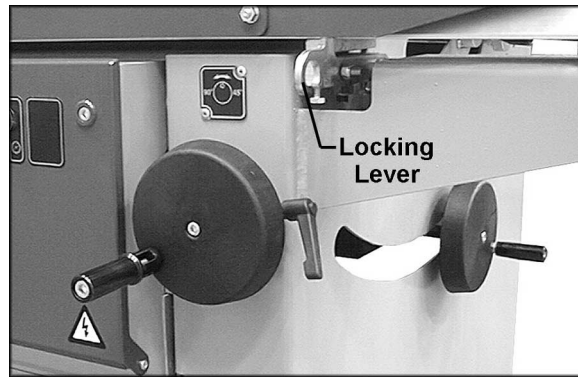

Figure 24

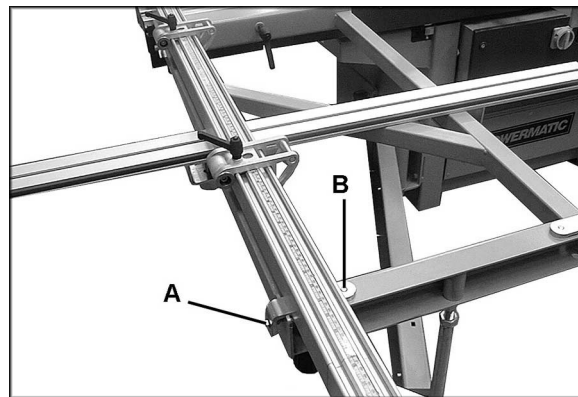

Figure 25

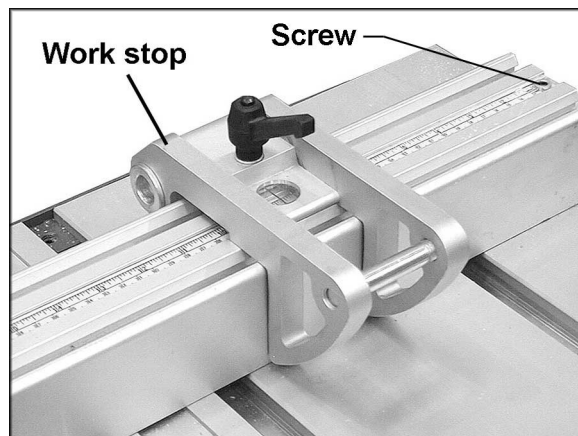

Figure 26

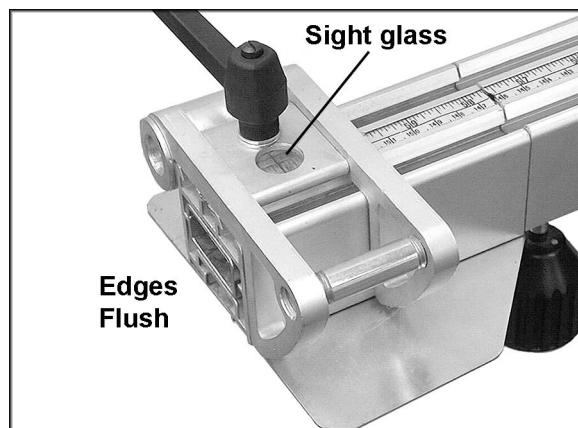

Figure 27

4. Record the measurement in the sight glass.
5. Add 2" to this measurement and slide out the extension until the new measurement is read at the end of the fixed fence (Figure 28). NOTE: Be careful to set this correctly, because the scale on the sliding fence reads opposite the scale on the fixed fence.
6. Lock the extension fence to this new measurement by tightening the knob underneath.
7. With a 3mm hex wrench, loosen the set screws underneath the short movable fence extrusion (Figure 29), and slide the extrusion to 2" of the fixed fence (Figure 30). Tighten the set screws.
8. When using the telescopic extension, make sure the stop is positioned flush with the end of the movable extrusion.
9. The best way to check if all scales correspond is to make several test cuts on the different scales.

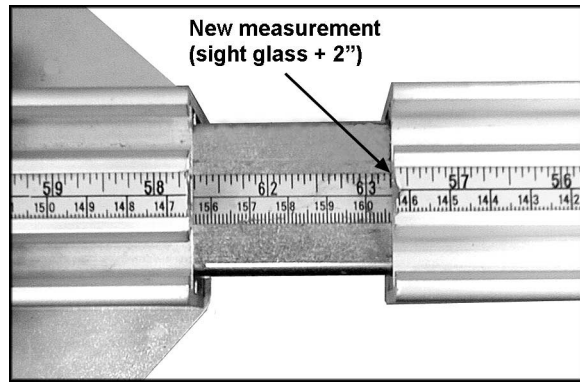

Figure 28

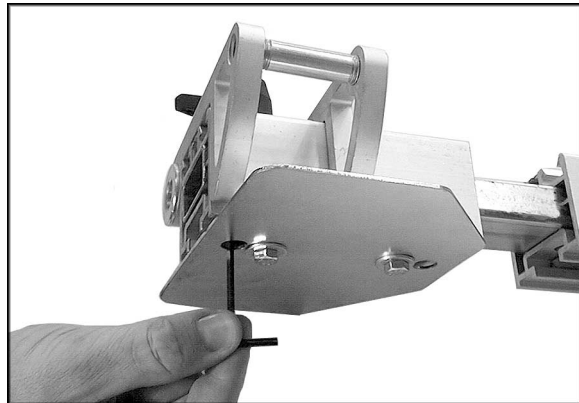

Figure 29

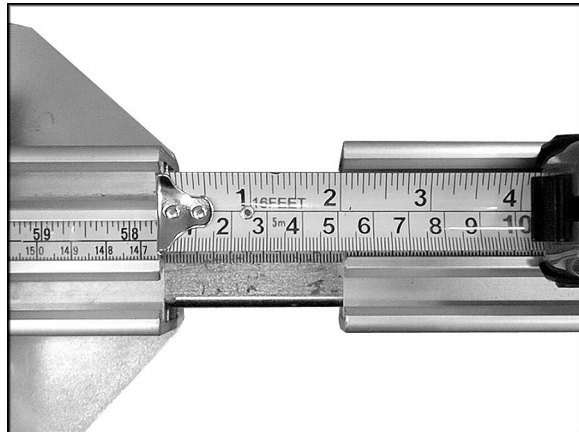

Figure 30

Wood Cap

After a period of use, if the wood protection cap at the end of the crosscut fence is cut away, a new one must be made. See Figure 31 for the correct dimensions.

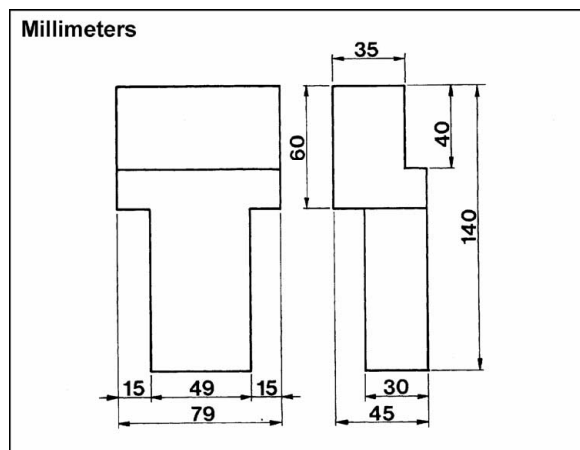

Figure 31

Miter Fence

The flat T-nut which holds the vertical rod of the clamp is factory set and must remain in its position to make the angle scale correspond.

1. To set the required angle, loosen the rod (A, Figure 32) with the provided pin as shown. Loosen the large lever (B, Figure 32).
2. To slide the fence (C, Figure 32) toward or away from the saw blade, unlock the two smaller levers.
3. Reading the angle is done at the edge of the aluminum bracket. An adjustable stop can be mounted to the miter fence as shown in Figure 32, for making multiple cuts of the same length.

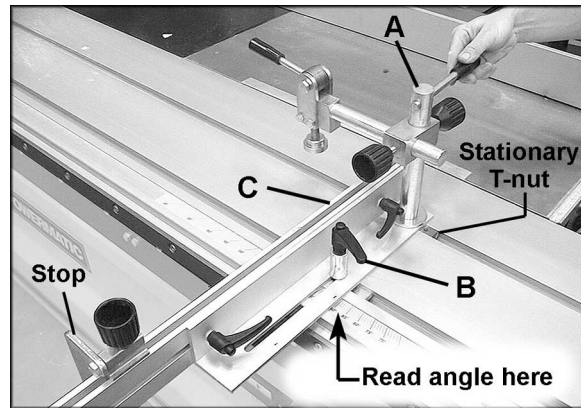

Figure 32

Rip Fence

1. To move the rip fence, shown in Figure 33, turn the micro-adjust gear counterclockwise, and lift the handle. The fence should slide freely on the guide bar.
2. To lock the fence in position, push the handle down and tighten the micro-adjust gear by turning it clockwise.
3. Micro-adjustment is achieved by locking the micro-adjust gear, by holding the handle in the upright position, and by turning the micro-adjust knob.
4. After adjustment, push handle down to lock the fence in place.

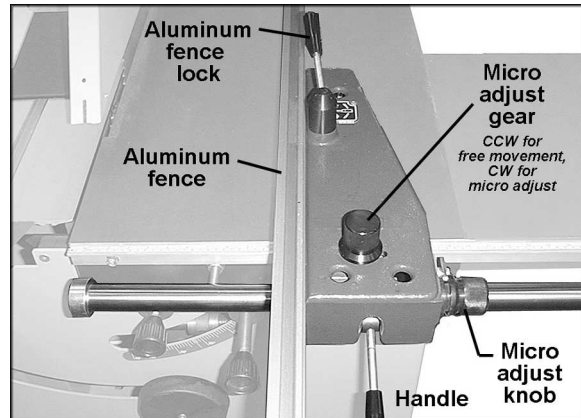

Figure 33

NOTE: When cutting small workpieces with the saw blade tilted at 45 degrees, the aluminum rip fence should be used in the low position:

1. Loosen the aluminum fence lock, slide the fence off and slide it back on in the low position, as shown in Figure 34.
2. Tighten the aluminum fence lock.

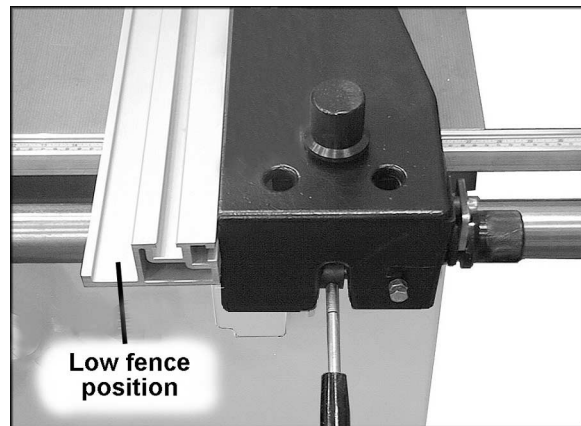

Figure 34

When cutting solid wood using the rip fence, to avoid the wood getting stuck between the fence and riving knife (which can result in a dangerous kickback) reposition the aluminum fence so that its end protrudes just past the end of the riving knife.

Rip Fence Scale Calibration

Each time a new blade is mounted, the rip fence scale has to be calibrated to the new blade.

With the fence at a convenient spot, cut a sample and measure its exact width.

Loosen the three screws on the scale (Figure 35) and nudge the scale until it matches the cut measurement. Make another cut to confirm the measurement.

To avoid the fence contacting the rotating saw blade, the stop ring must be adjusted.

Slide the fence to about 10mm from the saw blade.

Slide the stop ring across the round guide bar until it comes up against the casting of the fence. Tighten the set screw on the stop ring.

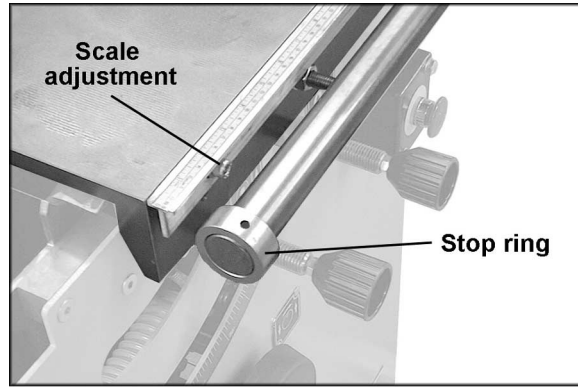

Figure 35

Tensioning the Belt

To tension the belt on the main motor:

1. Remove the access door and loosen the four bolts (Figure 36) which hold the motor.
2. Tension the belt by pushing the motor to the right, and tighten the four bolts.

CAUTION Make sure the belt is not over-tensioned as this may lead to damage to the saw arbor and belt.

To tension the belt on the scoring motor:

1. Loosen the two nuts (Figure 37) which hold the scoring motor.
2. While pushing the motor down, tighten the two nuts.

When replacing belts on the main or scoring motor, make sure the belt is well positioned into the v-groove of the pulley.

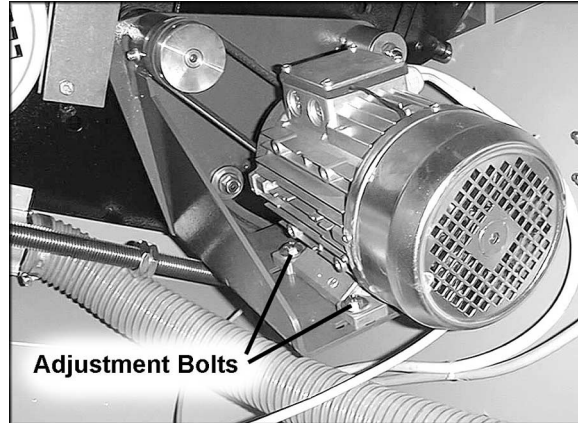

Figure 36

Precision Tuning Your Panel Saw

Your HPS67 is a precision machine designed to give accurate performance over many years. But like all fine equipment, it can only meet the tight tolerances required if it is tuned correctly.

Your machine has been so designed that all the major parameters which influence the quality of cut can be adjusted by non-technical staff.

These tuning procedures should be carried out in the proper order, as later adjustments depend upon the earlier being correct.

The four steps of the procedure are:

1. Free Cut from blade to sliding table
2. Free Cut from blade to rip fence
3. Square Cut
4. Scoring Saw

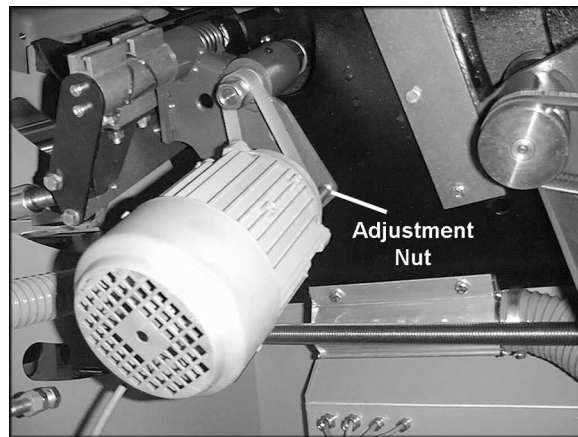

Figure 37

Free Cut (Blade to Sliding Table)

The sliding table does not run exactly parallel to the saw blade. It runs away from the back teeth by a fraction of a millimeter. This is called "free cut."

A very slight amount of free cut is desirable to avoid the problems of back cutting due to saw blade flutter. All saw blades vibrate to some extent. They flutter less at the front, where the cutting teeth are held stable by the material, than at the back.

If the table were set absolutely parallel to the saw blade, the back teeth could contact the material and spoil the clean cut achieved by the front teeth. As the back teeth are ascending, they could cause chip out on the top surface of laminated boards.

The free cut required is less than .05 mm over one meter of travel.

A dial indicator is not required. You can use your ears to compare the noise of the front teeth with that of the back teeth. To do this will require a workpiece shorter than the distance between front and back teeth. The saw blade should be raised to its maximum height to achieve the most contrast.

1. Lay the workpiece against the crosscut fence and make a cut.
2. Hold the workpiece firmly after the front teeth have cut and push it on past the back teeth. As you pass the back teeth you should feel rather than hear a slight tingling or whisper. If there is no sound from the back teeth, you probably have too much ("positive") free cut. If the noise from the back teeth is similar to that of the front teeth, there is too little ("negative") free cut and the table is running in towards the back of the blade.
3. Having passed the back teeth, stop level with the riving knife and cut backwards. The back teeth will make a noise as they are now cutting the material.

▲WARNING The workpiece must be held down firmly when making this backward cut.

4. As you continue past the front teeth, the noise from the front teeth should be equal to or slightly less than the noise from the back teeth. Slight back cutting on the backstroke equals slight free cut on the forward stroke.
5. If the front teeth make more noise than the back, the free cut is positive; if they make no noise, the free cut is negative. If the noise relationship front teeth to back teeth on the

forward stroke is the same as the noise relationship back teeth to front teeth on the back stroke (on a scale of 100, 100/30 in each case), the sliding table is running exactly parallel to the blade (zero free cut).

To correct the free cut, one end of the sliding table must be moved outward or inward. It doesn't matter whether you move the left or the right end. The only consideration is that there is enough clearance between the sliding table and the fixed cast iron table at the end you are moving.

1. At the end you have decided to move, loosen the hex nut (A, Figure 38) holding the sliding table to the frame.

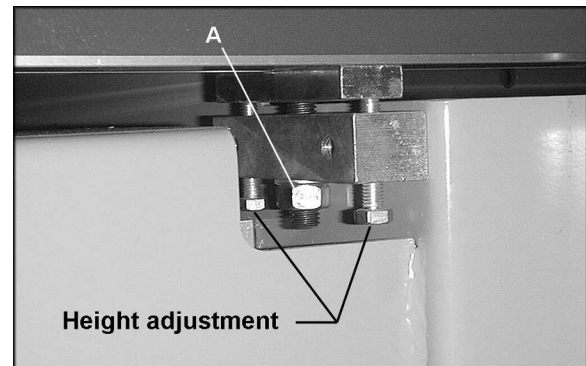

Figure 38

2. Loosen the other two hex nuts in the middle of the sliding table so that the table will pivot at the remaining fixed end.
3. Move the table end in or out as needed then retighten the table mounting nuts.
4. Check again to confirm the free cut is satisfactory. Repeat the process if needed.

NOTE: The sliding table should be approximately 0.3 mm higher than the fixed cast iron table (thickness of a piece of paper). This is pre-set at the factory, but if adjustment should ever be needed, use the four height adjustment bolts (Figure 38) on each end of the table.

Trouble-shooting Free Cut (Blade to Sliding Table):

Symptoms of positive free cut:

Back cutting on rip fence side. Workpiece on cast iron table pulled into back of sawblade.

Chip out on top.

Machine cutting out of square. Workpiece moves slightly on sliding table due to pressure of saw blade, without operator noticing.

Scoring saw correctly aligned for sliding table is out of alignment on rip fence side and vice-versa.

Chip out on the bottom as alignment of scoring saw with main blade inconsistent due to movement of workpiece.

Symptoms of negative free cut:

Back cutting on sliding table side. Workpiece runs into back of saw blade. Chip out on top.

Machine cutting out of square. Workpiece moves slightly on sliding table due to pressure of saw blade, without operator noticing.

Chip out on the bottom as alignment of scoring saw with main blade inconsistent due to movement of workpiece.

NOTE: The above test depends upon the riving knife being properly in line with the blade.

Free Cut (Blade to Rip Fence)

If the free cut on the rip fence side is negative, the symptoms are fairly obvious. The workpiece gets stuck between the back teeth and the fence and, in the worst case gets kicked back.

If the free cut is positive, other problems arise which are not so easily recognized, as for example, an incorrect rip fence setting. The following procedure will help you compare the distance between front teeth and rip fence with the distance between back teeth and rip fence:

1. Lower scoring blade all the way down, and out of the way.
2. Raise main blade to its highest position.
3. Take a workpiece of convenient size (e.g. 12" x 18") and edge one long side using the sliding table.
4. Set the rip fence slightly narrower than the workpiece, and cut the opposite long side of the workpiece using the fence.
5. Stop the workpiece when the trailing edge is level with the riving knife (i.e. has passed the back teeth.)
6. Using the rip fence micro adjustment, move the rip fence 1/4 turn inward, and pull workpiece backward almost to sawblade middle. The back teeth will then cut, and where they have cut, the workpiece width will correspond to the distance between the back teeth and the rip fence.
7. Remove workpiece in normal cutting direction.
8. Flip the workpiece over so that the trailing edge becomes the leading edge and feed

into the saw blade for half the direction which the back teeth just cut. The width here will correspond to the distance between the front teeth and the fence.

Between the teeth marks from the back teeth and front teeth there will be a small ridge. The height of this ridge is the free cut over the length of the saw blade. This ridge should hardly be visible, but just possible to feel.

To correct the free cut:

Loosen the nuts on the outside (third) bolt holding the guide bar on which the rip fence slides. See Figure 39.

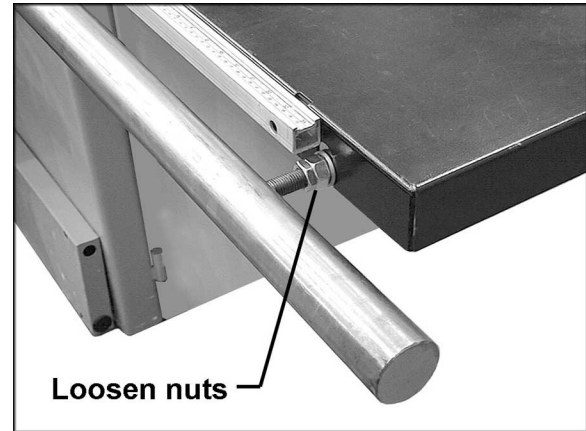

Figure 39

Move the bar, and therefore the fence, in or out by pivoting it upon the second bolt.

When corrected, tighten outside (third) bolt.

Trouble-shooting Free Cut (Blade to Rip Fence)

Symptoms of negative free cut:

Workpiece gets jammed between fence and back of saw blade, danger of kickback.

Backcutting, top chip out to the right of blade.

Symptoms of positive free cut:

Backcutting to the left of saw blade. Workpiece on left is pulled into back teeth. Chip out on top.

Scoring saw, while correctly aligned on sliding table side, is out of alignment for ripping.

When the rip fence section is in a pulled back position, the actual width cut is less than that shown on the scale.

NOTE: The above check depends on the riving knife being in line with the blade, not bent, narrower than the tooth kerf and wider than the body of the blade.

Square Cut

1. Take a panel approximately 40" and cut five times round, always turning the cut edge up against the crosscut fence (counter-clockwise with crosscut fence in normal position). The fifth cut cuts the same edge as the first.
2. The last offcut strip (whose left side was the last cut and whose right side was the first cut) must be the same width at both ends if every corner was precisely 90 degrees. Any error in the squareness has been multiplied four times.
3. Break the strip and lay the ends side by side and check the difference. (Break the strip in such a way that you know afterward which was front and which was back; e.g. front bit short, back bit long).

Unlike other methods of checking for squareness, this system tells you which way to move the fence should adjustment be necessary. It depends upon the shape of the fifth offcut strip:

If front thick, back thin – move fence counter-clockwise.

If front thin, back thick – move fence clockwise.

1. The crosscut fence position is adjusted at the outer attachment point only. Loosen the clamping device on the bottom of the crosscut fence.
2. Loosen the adjust the cross cut fence bracket on the top surface of the table.
3. Re-tighten the cross cut fence clamp device.
4. Perform another test to check the setting.

NOTE: An incorrect free cut on the sliding table can affect the squaring; see "Free Cut (Blade to Rip Fence)"

Scoring Blade

The scoring blade should penetrate the material about 2mm.

Problems with the alignment of the scoring blade can normally be traced back to too much free cut. For this reason, the free cut must be checked for correctness before the scoring saw is adjusted.

For example, when the main blade is tilted to 45 degrees, the scoring blade may need to be readjusted sideways.

The tilt axis is independent of the free cut on the sliding table rip fence. The scorer alignment at 90 degrees takes the free cut into account.

Thus, the scorer and the main blade are slightly out of alignment with regard to the tilt axis.

As the blades are tilted to 45 degrees, this misalignment in the horizontal plane also becomes a misalignment in the vertical plane.

The scorer must, therefore, be "raised" (moved to the left) or "lowered" (moved to the right) depending on whether the free cut on the sliding table, or the rip fence, needs to be compensated for.

The free cut can influence the scoring cut; it is essential to carry out the first two free-cut tests mentioned above before adjusting the scoring blade.

Operation

The panel saw is designed for the following work and is equipped with safety devices for these particular procedures. It is not designed to work materials such as ferrous or non-ferrous metals.

Available procedures:

- Ripping with the parallel saw fence with or without the saw blade tilted and the fence upright or in the low position.
- Right-angled or mitre cuts with the 90 degree fence mounted to the sliding table with tilted or vertical saw blade.
- Crosscutting workpieces using the adjustable stop on the 90 degree fence.
- Cutting panels or solid wood on the sliding table.

The machine has overload protection on both main and scoring motors. Should the motor be shut off by one of these protectors, it is necessary to wait a few minutes until the overload has cooled down before restarting.

Maintenance

The sliding table should be cleaned once a week, and all sawdust and chips removed.

From both sides of the sliding table, blow out the dust which has accumulated between the two sections and on the ball carrier. This can be done more efficiently when the upper part of the sliding table is slid to the rear. Then repeat the process when the upper part is slid to the front end.

Remove any resin deposits on sliding table and other surfaces.

After blowing out the dust, spray a thin oil onto the steel rods (Figure 40) on both the upper and lower part of the sliding table. Never use a thick oil or grease!

Lubricate all moving parts with a light coating of oil.

NOTE: All bearings in the machine are self-sealed and require no lubrication.

Blow sawdust out of the cooling fan and motor.

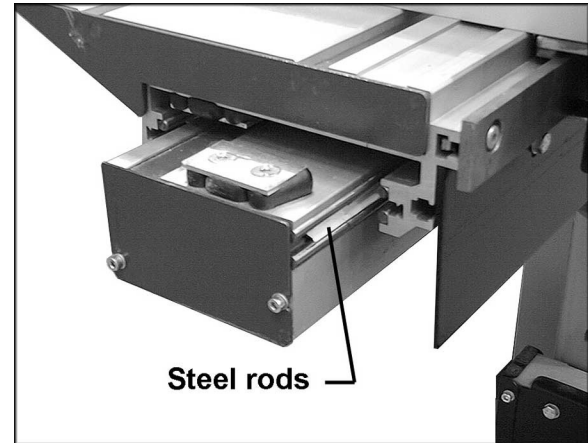

Figure 40

Troubleshooting

Trouble	Probable Cause	Remedy
Machine will not start when start button is pushed.	Access door open.	Close door completely.
	No power; possible shortage.	Check power source.
	Star-delta switch in wrong position.	Switch must be on "Y" position.
	Main switch off.	Put main switch on "1".
Excessive vibration.	Tilt or raising lock knobs not tight.	Tighten knobs.
	Blade out of balance.	Have it balanced or replaced.
	Worn or damaged belt.	Replace belt.
	Bad motor.	Replace motor.
Cuts out-of-square when crosscutting.	Fence misaligned.	Reset fence angle.
	Table not aligned with blade arbor.	Realign table.
Motor stalls or workpiece binds or burns.	Excessive feed.	Reduce feed.
	Dull or incorrect blade.	Replace blade.
	Bad motor.	Replace motor.
	Fence misaligned.	Realign fence.
Tilt or saw raising handwheels difficult to turn.	Lock knob not released.	Loosen lock knob.
	Worm and worm gear segment caked with sawdust and pitch.	Clean and re-grease.
	Worm and worm gear segment out of alignment.	Realign worm and worm gear segment.
After starting, arbor won't turn and motor makes straining noises.	Pin not removed from arbor hole after changing blade.	Remove pin.
Motor overheats.	Motor overloaded.	Correct overload condition such as reducing feed rate.
	Improper cooling of motor.	Clean sawdust from fan and duct areas of motor.
Thermal overload.	Overload not set on automatic reset, or overload is faulty.	Contact service technician.
Motor starts slowly or fails to come up to full speed.	Low voltage.	Request voltage check from power company and correct low voltage condition.
	Start switch malfunction.	Replace switch.
	Bad motor.	Replace motor.

Trouble	Probable Cause	Remedy
Reduction of speed during cutting.	Belt tension incorrect.	Properly tension belt.
	Motor overload due to incorrect feed rate.	Reduce feed rate.
	Dull blade(s).	Resharpen or replace.
Motor fails to develop full power.	Power line overloaded.	Correct overload condition.
	Undersize wires in supply system.	Increase supply wire size.
	Low voltage.	Request voltage check from power company and correct condition.
	Bad motor.	Replace motor.

Optional Accessories

6080152	Saw Blade, 120mm/24T, 20mm Bore
6080153	Saw Blade, 12"/72T, 30mm Bore
HPS67-159	Dado Bushing 1"

Replacement Parts

Replacement parts are listed on the following pages. To order parts or reach our service department, call 1-800-274-6848 between 7:30 a.m. and 6:00 p.m. (CST), Monday through Friday. Having the Model Number and Serial Number of your machine available when you call will allow us to serve you quickly and accurately.

Parts List: Motor and Arbor Assembly

Index No.	Part No.	Description	Size	Qty
1	HPS67-101	Collar		1
2	HPS67-102	Arbor Shaft		1
3	HPS67-103	Shaft		1
4	HPS67-104	Bushing		1
5	HPS67-105	Retainer Ring		1
6	HPS67-106	Bracket		1
7	HPS67-107	Retainer Block		1
8	HPS67-108	Spacer		1
9	HPS67-109	Sleeve		1
10	HPS67-110	Motor Base		1
11	HPS67-111	Flange Washer		1
12	HPS67-112	V-Belt		2
13	HPS67-113	Arbor Pulley		1
14	HPS67-114	Shaft		1
15	HPS67-115	Hose Clamp		3
16	HPS67-116	Riving Knife Holder Plate		1
17	HPS67-117	Spacer		1
18	HPS67-118	Strap Bracket		1
19	HPS67-119	Flange Nut Height Adjustment		2
20	HPS67-120	Spacer		2
21	HPS67-121	spacer		1
22	HPS67-122	Nut Inclination		2
23	HPS67-123	Motor Pulley		1
24	HPS67-124	Bracket		1
25	HPS67-125	Bracket		1
26	HPS67-126	Riving Knife	250/300	1
27	HPS67-127	Bracket		1
31		Saw Blade (not included)		1
32	HPS67-132	Spring		1
33	HPS67-133	Handwheel		1
34	HPS67-134	Pin	Φ 4 x 24mm	1
35	HPS67-135	Handwheel Mouting Handle		1
36	HPS67-136	Handwheel		2
37	HPS67-137	Collar		1
38	HPS67-138	Stud	M8 x 60	1
39	HPS67-139	Bushing		2
40	HPS67-140	Spindle		1
41	HPS67-141	Plate		1
42	HPS67-142	Mount Bracket		1
43	HPS67-143	Spindle Bracket		1
44	HPS67-144	Spindle		1
45	HPS67-145	Cover Tube		1
46	HPS67-146	Plate		2
47	HPS67-147	Plate		1
48	HPS67-148	Handle		1
49	HPS67-149	Strap Bracket		1
50	HPS67-150	Tube		1
51	HPS67-151	Sleeve		1
52	BB-6003ZZ	Ball Bearing		2
53	HPS67-153	Stud	M12 x 50	2
54	HPS67-154	Motor	5HP, 3Ph, 230V	1
	HPS67-154A	Motor	3HP, 1PH, 230V	1
55	HPS67-155	Bolt Handwheel		1
56	HPS67-156	Bracket		1
57	TS-1504051	Socket Head Cap Screw	M8 x 25	1
58	TS-1504041	Socket Head Cap Screw	M8 x 20	5
60	TS-1541031	Nylon Lock Hex Nut	M8	2

61	TS-1490031	Hex Head Cap Screw	M8 x 20	1
62	TS-1540061	Full Hex Nut	M8	6
63	TS-2238751	Socket Head Cap Screw	M8 x 75	1
64	TS-1504131	Socket Head Cap Screw	M8 x 70	2
65	TS-2239101	Socket Head Cap Screw	M10 x 8	1
66	TS-1505011	Socket Head Cap Screw	M10 x 16	2
67	HPS67-157	Flange Washer		1
68	TS-2360101	Flat Washer	M12	2
69	TS-2342121	Full Nylon Inset Lock Nut	M12	2
70	TS-1490041	Hex Cap Screw	M8 x 25	4
71	TS-2312241	Hex Jam Nut	M24	4
72	TS-1504011	Socket Head Cap Screw	M8 x 10	1
73	TS-1516031	Flat Head Socket Cap Screw	M10 x 30	1
74	TS-1506051	Socket Head Cap Screw	M12 x 40	1
75	TS-1524011	Socket Set Screw	M8 x 8	4
76	TS-1490061	Hex Head Cap Screw	M8 x 35	1
77	TS-2361081	Lock Washer	M8	1
78	TS-1524041	Socket Set Screw	M8 x 16	2
79	TS-1490081	Hex Head Cap Screw	M8 x 45	3
80	TS-1514051	Flat Head Socket Cap Screw	M6 x 30	1
81	TS-1541021	Nylon Lock Hex Nut	M6	1
82	TS-1550041	Flat Washer	M6	1
83	HPS67-158	Dado Bushing	30mm	1
84	TS-1522061	Socket Set Screw	M5 x 20	2

Parts List: Scoring Motor and Arbor Assembly

Index No.	Part No.	Description	Size	Qty
1	HPS67-201	Collar		1
2		Scoring Blade (not included)		1
3	HPS67-203	Arbor Shaft		1
4	HPS67-204	Bushing		1
5	HPS67-205	Sleeve		1
6	HPS67-206	V-Belt		1
7	HPS67-207	Arbor Pulley		1
8	HPS67-208	Tilt Bracket		2
11	HPS67-211	Micro Switch		1
14	HPS67-214	Handle Knob		1
15	HPS67-215	Bushing		1
17	HPS67-217	Bracket		1
18	HPS67-218	Adjustment Screw		1
19	HPS67-219	Block		1
20	HPS67-220	Arbor Housing		1
21	HPS67-221	Shaft		1
22	HPS67-222	Shaft Guide		1
23	HPS67-223	Shaft Bracket		1
24	HPS67-224	Guide Bracket		1
25	HPS67-225	Spring		1
26	HPS67-226	Motor Pulley		1
27	HPS67-227	Strap Bracket		1
28	HPS67-228	Bushing		1
32	HPS67-232	Saw Unit Assembly		1
33	HPS67-233	Scoring Motor	3/4HP, 230V	1
35	BB-6003ZZ	Ball Bearing	6003ZZ	2
36	BB-608ZZ	Ball Bearing	608ZZ	2
37	TS-1504041	Socket Head Cap Screw	M8 x 20	1
38	TS-1515021	Flat Head Socket Cap Screw	M8 x 20	1
39	TS-1515031	Flat Head Socket Cap Screw	M8 x 25	1
40	TS-1515011	Flat Head Socket Cap Screw	M8 x 16	1
41	TS-2248162	Socket Head Button Screw	M8 x 16	2
42	TS-1550041	Flat Washer	M6	2
43	TS-1550061	Flat Washer	M8	7
45	TS-2311081	Hex Nut	M8	3
48	TS-1501081	Socket Head Cap Screw	M4 x 30	1
51	TS-1490031	Hex Head Cap Screw	M8 x 20	2
52	TS-1490021	Hex Head Cap Screw	M8 x 16	2
53	TS-2310162	Hex Nut	M16	1
54	TS-1522041	Socket Set Screw	M5 x 12	1
55	TS-1504021	Socket Head Cap Screw	M8 x 12	2
56	TS-1524031	Socket Set Screw	M8 x 12	1
57	TS-1503131	Socket Head Cap Screw	M6 x 60	1
58	TS-1490011	Hex Head Cap Screw	M8 x 12	3
59	TS-1482021	Hex Cap Screw	M6 x 12	1
60	TS-1550041	Flat Washer	M6	2
61	HPS67-261	Plate		1
62	HPS67-262	Cover		1
63	TS-1540041	Hex Nut	M6	2
64	HPS67-264	Brush		1
65	TS-1490091	Hex Cap Screw	M8 x 50	1
66	HPS67-266	Spacer		1
67	TS-1503041	Socket Head Cap Screw	M6 x 16	1
68	TS-1550061	Flat Washer	M8	1
69	HPS67-269	Support		1

70.....	HPS67-270.....	Mounting Bracket.....	1
71.....	HPS67-271.....	Dust Chute Assembly.....	1
72.....	HPS67-272.....	Spacer.....	2

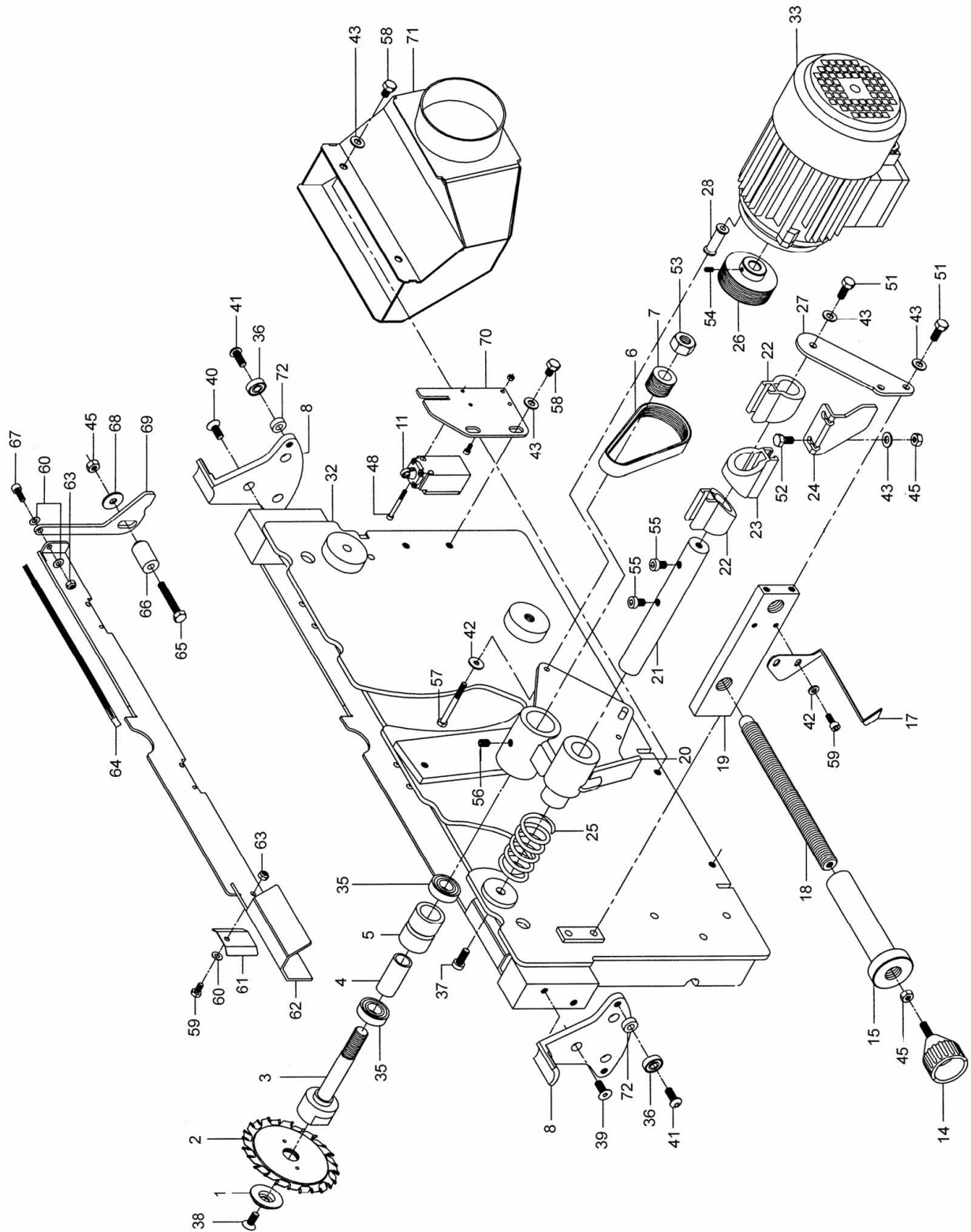

Parts List: Stand and Table Assembly

Index No.	Part No.	Description	Size	Qty
1	HPS67-301	Stand		1
2	HPS67-302	Table Extension		1
3	HPS67-303	Support Leg		1
4	HPS67-304	Table		1
5	HPS67-305	Table Saw Extension Right Z		1
6	HPS67-306	Door		1
8	HPS67-308	Base Plate		1
9	HPS67-309	Base Plate		1
10	HPS67-310	Base Plate		1
11	HPS67-311	Hook		1
12	HPS67-312	Threaded Rod		1
13	HPS67-313	Bushing		1
14	HPS67-314	Spacer Block		1
15	HPS67-315	Mount Plate		1
16	HPS67-316	Mount Block		1
17	HPS67-317	Spacer Block		1
18	HPS67-318	Bushing		1
19	HPS67-319	Mount Plate		1
20	HPS67-320	Housing		1
21	HPS67-321	Bushing		1
22	HPS67-322	Side Plate		1
23	HPS67-323	Bracket		1
24	HPS67-324	Spring		1
25	HPS67-325	Box		1
26	HPS67-326	Rod		1
27	HPS67-327	Wrench		1
28	HPS67-328	Wrench	12 x 17mm	1
29	TS-152707	Hex Wrench	6mm Short	1
30	TS-152706	Hex Wrench	5mm Short	1
31	TS-152705	Hex Wrench	4mm Short	1
32	TS-1550041	Flat Washer	M6	1
33	TS-2311061	Hex Nut	M6	1
34	TS-1514021	Socket Head Flat Screw	M6 x 16	1
35	TS-1490031	Hex Cap Screw	M8 x 20	1
36	TS-1550061	Flat Washer	M8	6
37	TS1504031	Socket Head Cap Screw	M8 x 16	1
38	TS-1504041	Socket Head Cap Screw	M8 x 20	1
39	TS-2361081	Lock Washer	M8	3
40	TS-1503041	Socket Head Cap Screw	M6 x 16	1
41	TS-2248501	Socket Head Flat Screw	M8 x 50	2
42	TS-1504101	Socket Head Cap Screw	M8 x 50	2
43	TS-1490011	Hex Head Cap Screw	M8 x 12	1
44	TS-1482021	Hex Head Cap Screw	M8 x 12	1
45	TS-2311081	Hex Nut	M8	2
46	TS-2311061	Hex Nut	M6	1
47	TS-1504071	Socket Head Cap Screw	M8 x 35	1
48	TS-1503011	Socket Head Cap Screw	M6 x 8	1
49	TS-1550061	Flat Washer	M8	1
50	TS-1490151	Hex Head Cap Screw	M8 x 80	2
51	TS-1515051	Flat Head Socket Cap Screw	M8 x 40	1
52	TS-154010	Hex Nut	M16	8
53	TS-155010	Flat Washer	M16	8
54	TS-1490101	Hex Head Cap Screw	M8 x 55	1
55	TS-1490041	Hex Cap Screw	M8 x 25	4
56	HPS67-356	Dust Hose		1
57	HPS67-357	Hose Clamp		1

58.....	TS-1540031.....	Hex Nut.....	M5.....	4
59.....	TS-1550031.....	Flat Washer.....	M5.....	8
60.....	HPS67-360.....	Interior Dust Chute.....		1
61.....	HPS67-361.....	Gasket.....		1
62.....	HPS67-362.....	Exterior Dust Chute.....		1
63.....	TS-1502051.....	Socket Head Cap Screw.....	M5 x 20.....	4

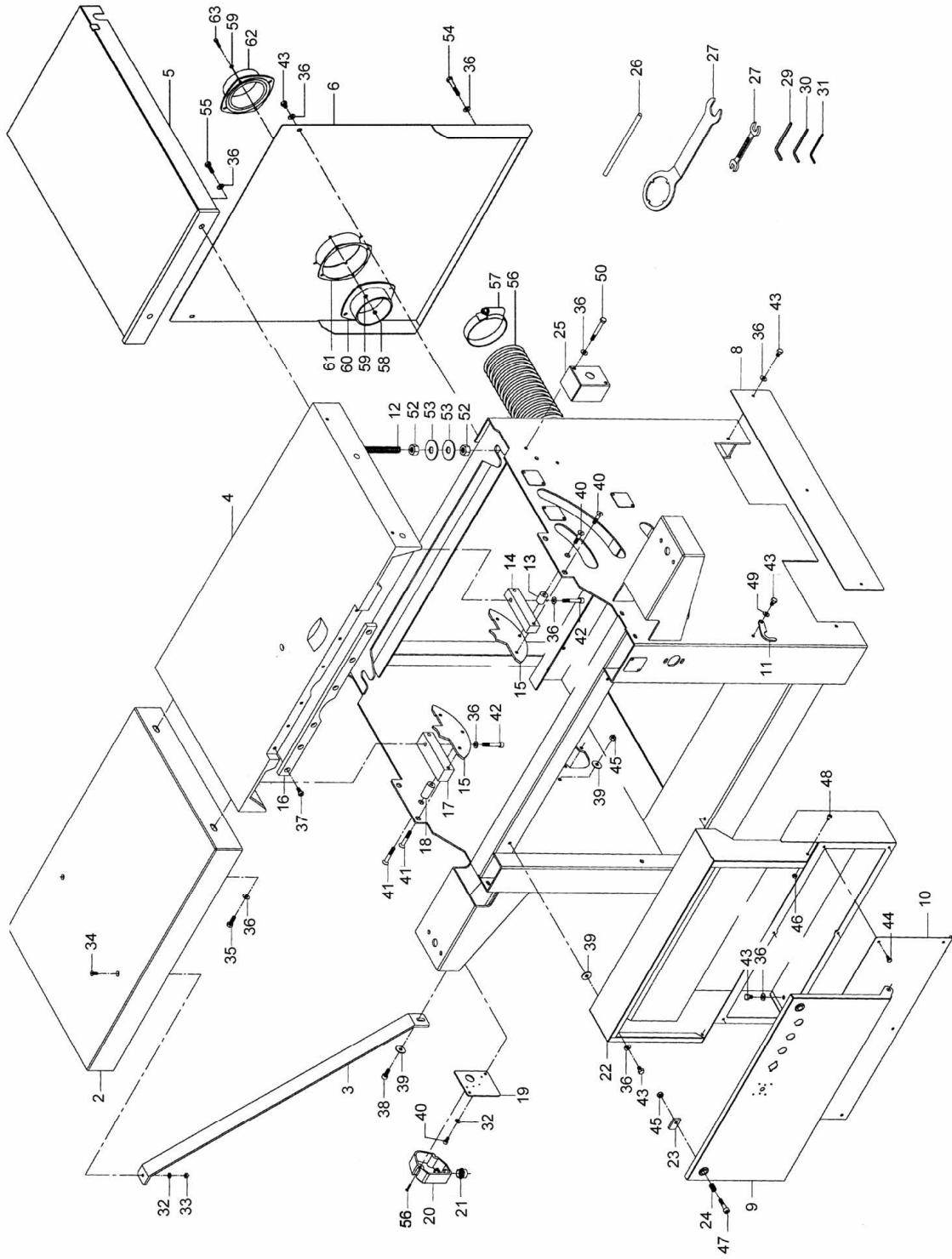

Parts List: Support Arm Assembly

Index No.	Part No.	Description	Size	Qty
1	HPS67-501	Support Arm		1
2	HPS67-502	Shaft		1
3	HPS67-503	Shaft		1
4	HPS67-504	Side Plate		1
5	HPS67-505	Roller		1
6	HPS67-506	Plug		2
7	HPS67-507	Arm Tube		1
8	HPS67-508	Brush		4
9	HPS67-509	Bracket		1
10	HPS67-510	Bracket		1
11	HPS67-511	Arm Bracket		1
12	HPS67-512	Pivot Shaft		1
13	HPS67-513	Spacer		1
14	HPS67-514	Spool		1
15	HPS67-515	Shaft		2
17	TS-154010	Hex Nut	M16	1
18	TS-1503031	Socket Head Cap Screw	M6 x 12	8
19	TS-1550041	Flat Washer	M6	8
20	HPS67-516	Retainer Ring		1
21	TS-2311081	Hex Nut	M8	5
22	TS-1550061	Flat Washer	M8	6
23	TS-1490021	Hex Head Cap Screw	M8 x 16	4
24	TS-2213801	Hex Head Cap Screw	M16 x 80	1
25	TS-155010	Flat Washer	M16	1
26	TS-1504031	Socket Head Cap Screw	M8 x 16	4
27	TS-1503041	Socket Head Cap Screw	M6 x 16	1
28	TS-1524061	Socket Set Screw	M8 x 25	1
29	TS-2210161	Hex Head Cap Screw	M10 x 16	1
30	TS-1550071	Flat Washer	M10	2
31	TS-1523061	Socket Set Screw	M6 x 20	1
32	TS-1504021	Socket Head Cap Screw	M8 x 12	1

Support Arm Assembly

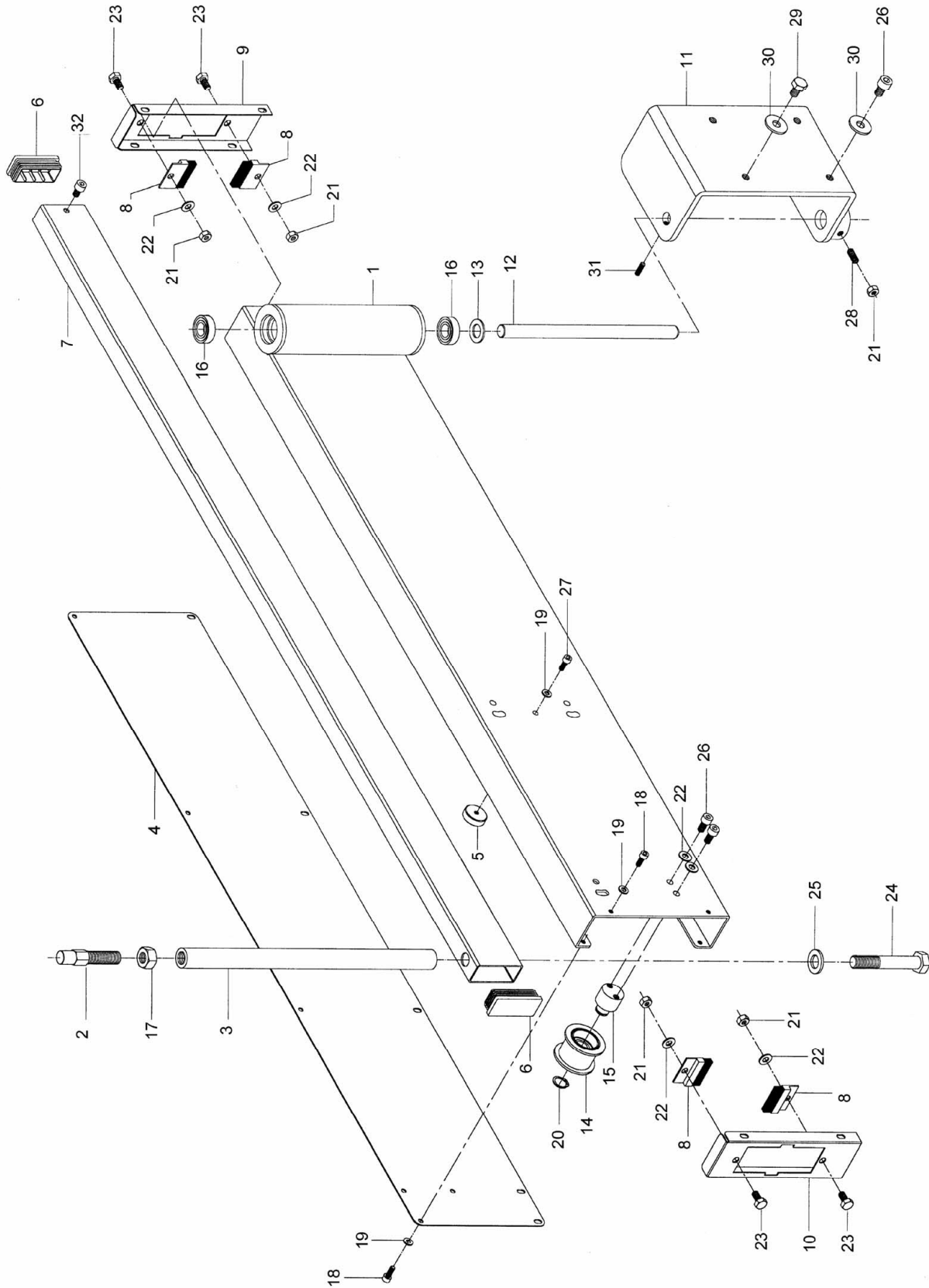

Parts List: Cross Cut Fence Assembly

Index No.	Part No.	Description	Size	Qty
1	HPS67-601	Cross Cut Fence		1
2	HPS67-129	Handle		1
3	HPS67-603	Flipper Bracket (Left)		2
4	HPS67-604	Pin		2
5	HPS67-605	Bracket Cursor		2
6	HPS67-606	Flipper Bracket (Right)		2
7	HPS67-607	Stop Bushing		4
8	HPS67-608	Fence Tube		1
9	HPS67-609	T-Bolt		1
10	HPS67-610	Fence Clamp		1
11	HPS67-611	Plate		1
12	HPS67-612	Mitre Bracket		1
13	HPS67-613	Hand Knob		1
14	HPS67-614	Square Nut		1
15	HPS67-615	Washer		2
16	HPS67-616	Bracket		2
17	HPS67-617	Clamp Nut		1
18	HPS67-618	Hand Knob		1
19	HPS67-619	Lock Knob		1
20	HPS67-620	Clamp		1
21	HPS67-621	Strap Bracket		1
22	HPS67-622	Adjustment Plate		1
23	HPS67-623	Bracket		1
24	HPS67-624	Bracket		1
25	HPS67-625	Fence Splitter Protector		1
26	HPS67-626	Self-Tapping Screw		1
27	TS-1541031	Hex Nylon Lock Nut	M8	2
28	TS-1504091	Socket Head Cap Screw	M8 x 45	2
29	TS-1523031	Socket Set Screw	M6 x 10	1
30	TS-1550041	Flat Washer	M6	1
31	TS-1482031	Hex Head Cap Screw	M6 x 16	1
32	TS-1550041	Flat Washer	M6	2
33	TS-1541021	Hex Nylon Lock Nut	M6	2
34	TS-2210161	Hex Head Cap Screw	M10 x 16	1
35	TS-1482061	Hex Head Cap Screw	M6 x 30	2
36	TS-1550071	Flat Washer	M10	2
37	TS-1524011	Socket Set Screw	M8 x 8	2
38	TS-2361081	Lock Washer	M8	1
39	HPS67-627	Cross Tube		1
40	HPS67-628	Handle		1
41	TS-1550071	Flat Washer	M10	1
42	TS-1490011	Hex Head Cap Scre	M8 x 12	1
43	TS-1550061	Flat Washer	M8	1
44	TS-1523011	Socket Set Screw	M6 x 6	2
45	TS-2246101	Flat Head Socket Cap Screw	M6 x 10	1

Cross Cut Fence Assembly

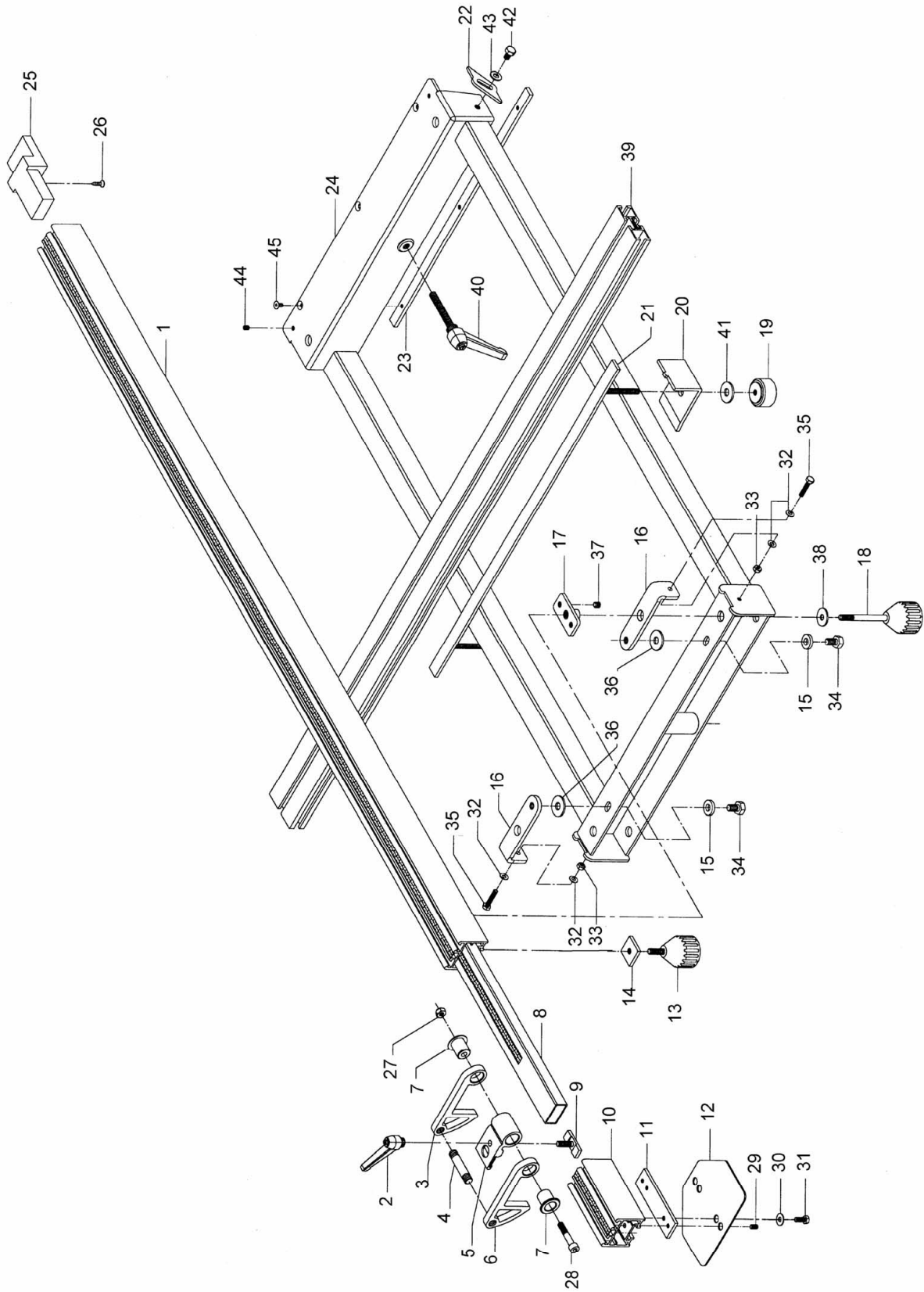

Parts List: Rip Fence Assembly

Index No.	Part No.	Description	Size	Qty
1	HPS67-445	Handle		2
2	HPS67-702	Stud		2
3	HPS67-703	Lock Bushing		1
4	HPS67-704	Bushing		1
5	HPS67-705	Sleeve		1
6	HPS67-706	Fence Bracket		1
7	HPS67-707	Spacer		2
8	HPS67-708	Fence		1
9	HPS67-709	Strap		1
10	HPS67-710	Stud		2
11	HPS67-711	Guide Bar		1
12	HPS67-712	Collar		1
13	HPS67-713	Spacer		1
14	HPS67-714	Parallel Scale		1
21	HPS67-721	Plate		1
22	HPS67-722	Adjustment Bracket		1
23	HPS67-723	Bushing		1
24	HPS67-724	Bar		1
25	HPS67-725	Guide Bolt		1
26	HPS67-726	Adjustment Lock Bolt		1
27	HPS67-727	Handle Plate		1
28	HPS67-728	Fine Adjustment Bolt		1
29	HPS67-729	Retainer Ring		2
30	HPS67-730	Eccentric Shaft		1
31	HPS67-731	Lock Collar		1
32	TS-1540081	Hex Nut	M12	4
33	TS-2360121	Flat Washer	M12	4
34	TS-1504041	Socket Head Cap Screw	M8 x 20	1
35	TS-154010	Hex Nut	M16	1
36	TS-2235601	Socket Head Cap Screw	M5 x 60	2
38	TS-1490071	Hex Head Cap Screw	M8 x 40	1
43	TS-1504061	Socket Head Cap Screw	M8 x 30	5
44	TS-1524011	Socket Set Screw	M8 x 8	1
45	TS-1524031	Socket Set Screw	M8 x 12	1
46	TS-1524051	Socket Set Screw	M8 x 20	1
47	TS-1550061	Flat Washer	M8	2
48	TS-1490061	Hex Head Cap Screw	M8 x 35	1

Rip Fence Assembly

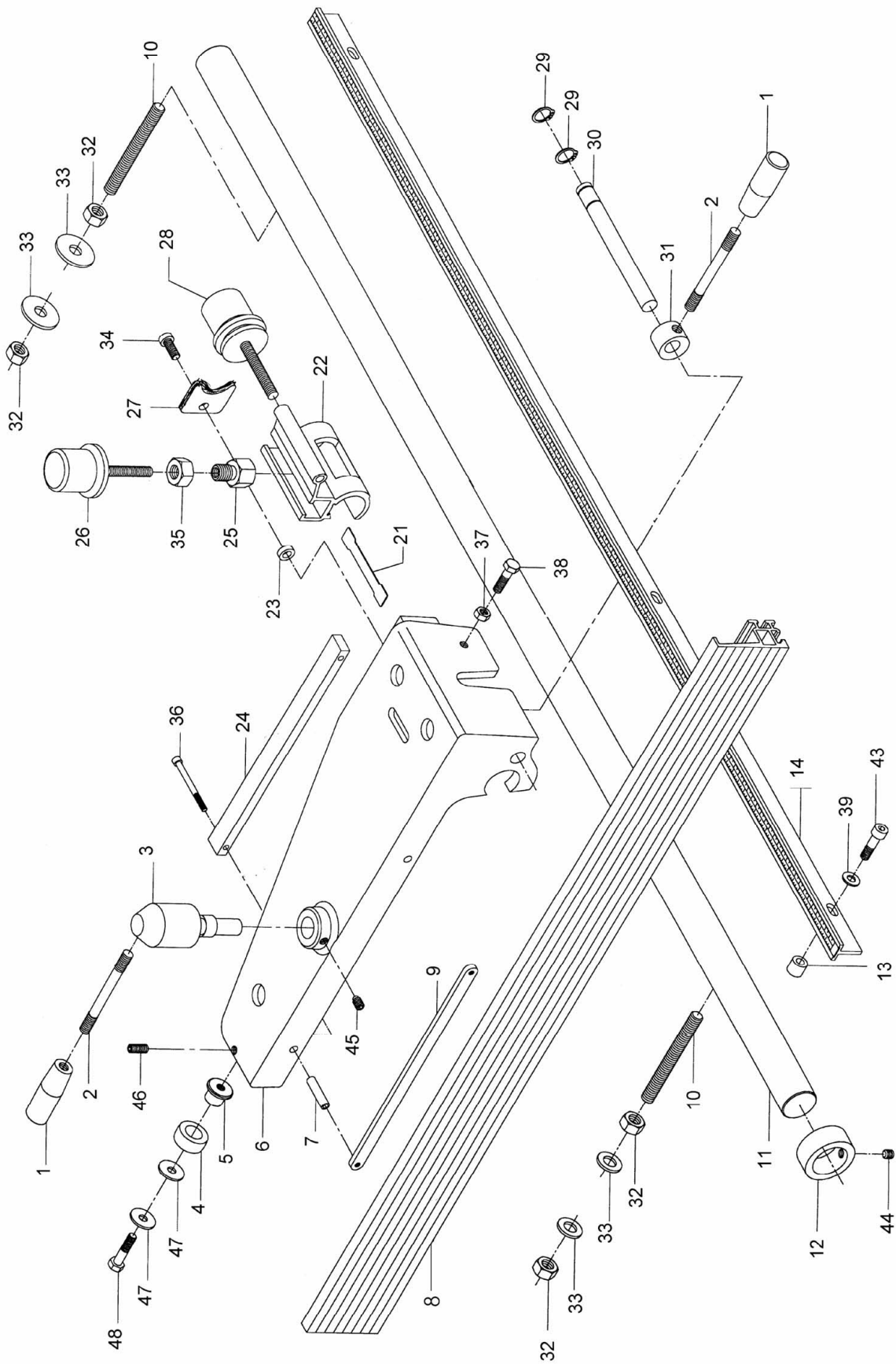

Parts List: Over Arm Guard Assembly

Index No.	Part No.	Description	Size	Qty
1	HPS67-901A	Over Arm Assembly		1
9	HPS67-909	Hand Knob		1
10	HPS67-910	End Cap		2
27	TS-1550061	Flat Washer	M8	12
29	TS-1505041	Socket Head Cap Screw	M10 x 30	4
30	TS-1550071	Flat Washer	M10	8
31	TS-2311101	Hex Nut	M10	5
32	TS-2311081	Hex Nut	M8	4
37	TS-1541031	Nylon Lock Hex Nut	M8	4
46	TS-1505131	Socket Head Cap Screw	M10 x 80	2
47	HPS67-947	Upper Guard (LH)		1
48	TS-1504011	Socket Head Cap Screw	M8 x 10	6
49	TS-1504031	Socket Head Cap Screw	M8 x 16	2
50	TS-1540031	Hex Nut	M5	1
51	HPS67-951	Stand Off		1
52	TS-1515031	Socket Head Flat Screw	M8 x 25	3
53	TS-2311081	Hex Nut	M8	4
54	HPS67-954	Bushing		2
55	HPS67-955	Link Bar		2
56	HPS67-956	Ball Bearing	6003-2RS	4
57	HPS67-957	Bushing		4
58	TS-1550061	Flat Washer	M8	2
59	HPS67-959	Spacer		2
60	HPS67-960	Handle		2
61	HPS67-961	Threaded Rod		1
62	HPS67-962	Guard Column (LH)		1
63	HPS67-963	Socket Set Screw	M8 x 30	1
64	HPS67-964	Pointer		1
65	TS-1490041	Hex Cap Screw	M8 x 25	1
66	HPS67-966	Upper Bracket		1
67	TS-1524021	Socket Set Screw	M8 x 10	4
68	HPS67-968	Lower Bracket		1
69	HPS67-969	Support Shaft		4
70	HPS67-970	Guard Column (RH)		1
71	HPS67-971	Bolt		1
72	TS-1502041	Socket Head Cap Screw	M5 x 16	
73	HPS67-973	Link Bar		2
74	HPS67-974	Socket Head Flat Screw	M8 x 45	1
75	HPS67-975	Cylinder		1
76	TS-149006	Hex Cap Screw	M8 x 35	1
77	HPS67-977	Bushing		2
81	HPS67-981	Upper Guard (RH)		1
	HPS67-982A	Blade Guard Assembly (tilted arbor) (items 71, 82 thru 88)		1
82	HPS67-982	Blade Guard (tilted arbor)		1
	HPS67-983A	Blade Guard Assembly (items 71, 83 thru 88)		1
83	HPS67-983	Blade Guard		3
84	TS-1540021	Hex Nut	M4	4
85	TS-1501051	Socket Head Cap Screw	M4 x 16	4
86	TS-1501091	Socket Head Cap Screw	M4 x 35	4
87	HPS67-987	Roller		4
88	HPS67-988	Lock Nut		1

Over Arm Guard Assembly

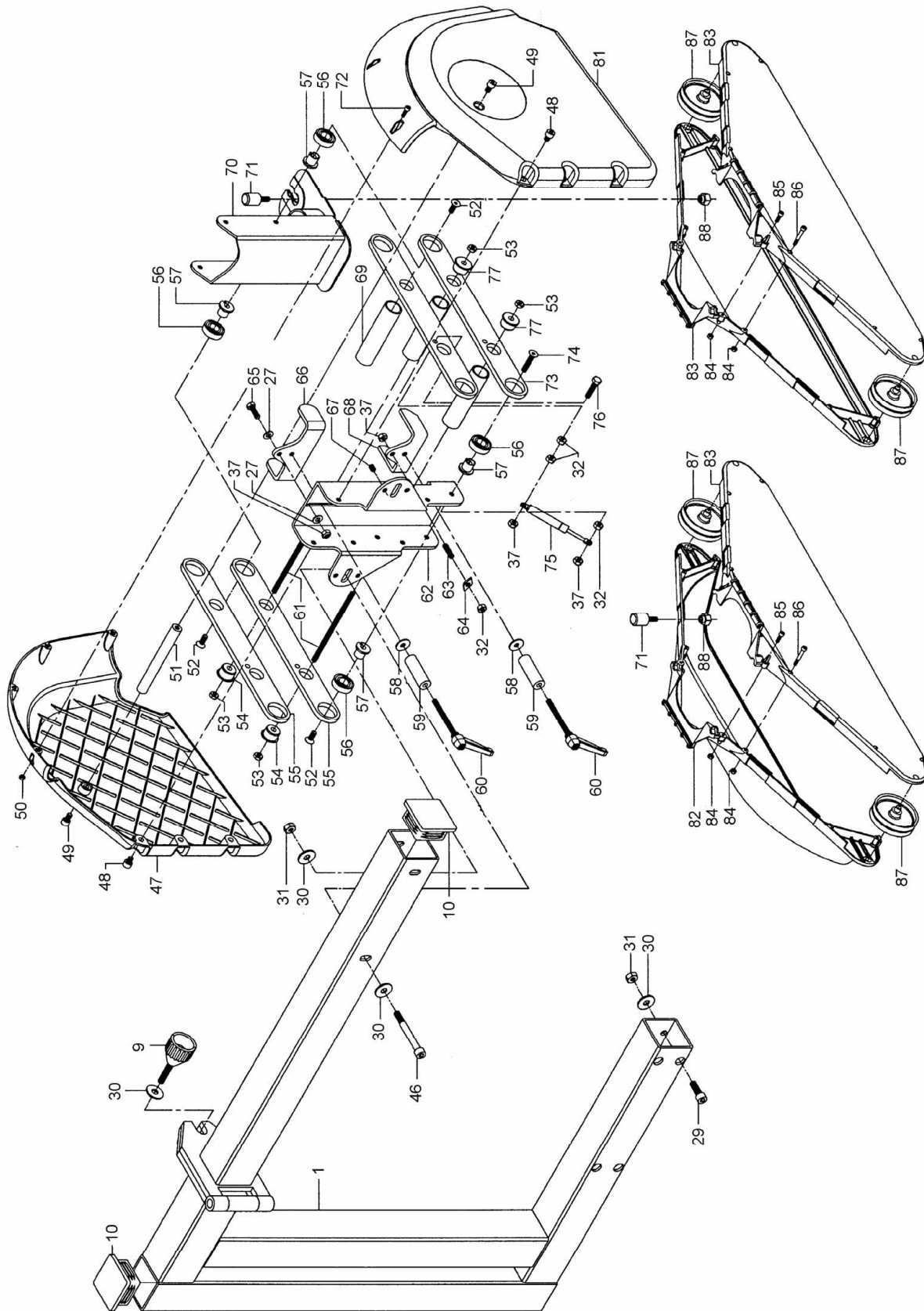

Parts List: Sliding Table Assembly

Index No.	Part No.	Description	Size	Qty
1	HPS67-401	Plate		1
2	HPS67-402	Mount Plate		1
3	HPS67-403	Steel Ball		30
4	HPS67-404	Plug		4
5	HPS67-405	Wiper		4
6	HPS67-406	Plate (1700)		1
7	HPS67-407	Cover Plate		2
8	HPS67-408	Strap Plate		1
9	HPS67-409	Adjustment Knob		2
10	HPS67-410	Adjustment Block		1
11	HPS67-411	Lock Plate		1
12	HPS67-412	Mitre Guide Stop		1
13	HPS67-413	Profile Tube		1
15	HPS67-415	Handle		1
18	HPS67-418	Plate		2
19	HPS67-419	Lock Profile		2
20	HPS67-420	Lock Plate		2
21	HPS67-421	Lock Block		2
22	HPS67-422	Profile Support (1700)		1
23	HPS67-423	Lock Slide Table		1
25	HPS67-425	Rod (1700)		8
27	HPS67-427	Rubber Buffer Plate		1
28	HPS67-428	Spacer		1
29	HPS67-429	Nut Plate		14
30	HPS67-129	Handle		2
31	HPS67-431	Handle Plate		1
33	HPS67-433	Profile Support Table (1700)		1
34	HPS67-434	Nut Plate		1
35	HPS67-435	Clamp		1
36	HPS67-436	Stop Plate		1
37	HPS67-437	Mount Plate (1700)		1
38	HPS67-438	Handle Bolt		2
39	HPS67-439	Bushing		1
40	HPS67-440	Handle		1
42	HPS67-442	Post Block		1
43	HPS67-443	Rod		1
50	HPS67-450	Stud	M10 x 20	4
51	TS-1490021	Hex Head Cap Screw	M8 x 16	1
52	TS-1491041	Hex Head Cap Screw	M10 x 30	1
53	TS-1550071	Flat Washer	M10	1
54	TS-1550061	Flat Washer	M8	10
55	TS-2311081	Hex Nut	M8	4
57	TS-2360121	Flat Washer	M12	2
58	TS-1540081	Hex Nut	M12	2
59	TS-1541021	Nylon Lock Hex Nut	M6	4
62	TS-1482031	Hex Head Cap Screw	M6 x 16	6
63	TS-1504101	Socket Head Cap Screw	M8 x 50	2
64	TS-1504121	Socket Head Cap Screw	M8 x 60	2
65	TS-1550061	Flat Washer	M8	1
66	TS-1541031	Nylon Lock Hex Nut	M8	2
67	HPS67-451	Stud	M8 x 20	6
68	HPS67-452	Self Tapping Screw		4
69	TS-1524031	Socket Set Screw	M8 x 12	2
70	TS-1515031	Flat Head Socket Cap Screw	M8 x 25	1
71	TS-1504031	Socket Head Cap Screw	M8 x 16	14
72	HPS67-453	Washer		1
73	TS-1504041	Socket Head Cap Screw	M8 x 20	5

79	HPS67-479	Post	1
80	HPS67-480	Handle	1
81	HPS67-481	Handle Shaft	1
82	HPS67-482	Cam	1
83	HPS67-483	Clamp Pin	1
84	HPS67-484	Spring	1
85	HPS67-485	Pin	1
86	HPS67-486	Clamp Block	1
87	HPS67-487	Clamp	1

Sliding Table Assembly

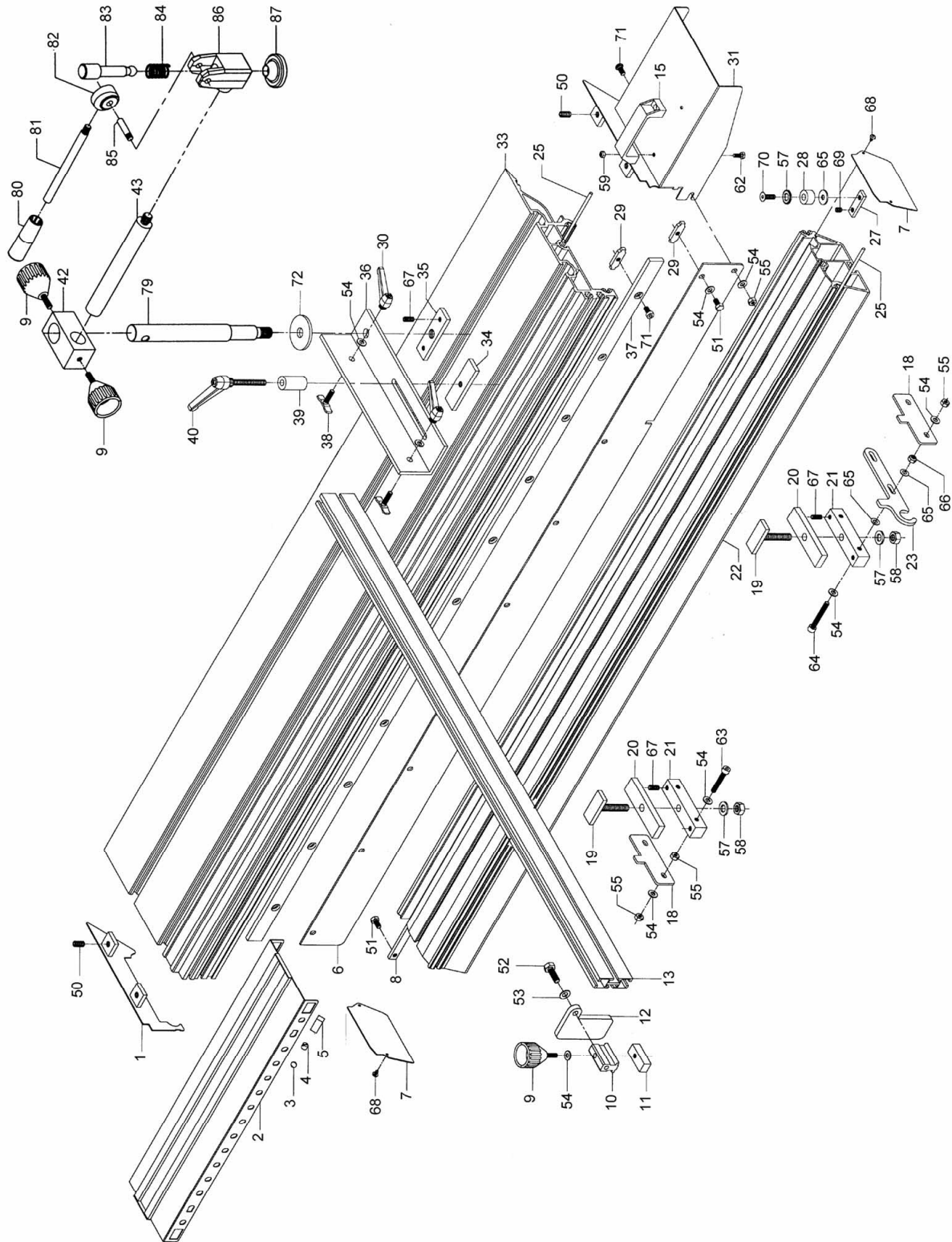

Parts List: Electrical Components – 3 Phase

(see page 44)

Index No.	Part No.	Description	Qty
Q1	HPS67-801	Main Switch	1
F1-3	HPS67-802	Fuse, 10 x 38mm (3.7kw 230V 3Ph 16A)	3
F7	HPS67-805	Fuse, 6 x 20mm (0.5A Primary Transformer AM)	1
F9	HPS67-806	Fuse, 6 x 20mm (2A Secondary Transformer GL)	1
	HPS67-807	Fuse Holder	1
T1	HPS67-808	Transformer, 230-400-24V 40VA	1
eb1	HPS67-809	Thermal Overload (9-13A 230V 3.7kw)	1
eb2	HPS67-810	Thermal Overload (2.8-4.4A 230V, 55kw)	1
AU1	HPS67-811	Emergency Stop Frame	1
AU2	HPS67-812	Emergency Stop Electrical Cabinet	1
SE1	HPS67-813	Micro Switch Saw Cover	1
S1	HPS67-814	Start Switch, 3Ph (Saw Motor)	1
S2	HPS67-815	Start Switch, 1Ph (Scoring Motor)	1
S5	HPS67-816	Star-Delta Switch (3.7kw)	1
KM1	HPS67-817	Magnetic Starter (3.7kw 230V AB-C12) Saw Motor	1
KM2	HPS67-818	Magnetic Starter (.55kw 230V AB-C12) Scoring Motor	1

Parts List: Electrical Components – 1 Phase

(see page 45)

Index No.	Part No.	Description	Qty
Q1	HPS67-801	Main Switch	1
F1-2	HPS67-820	Fuse, 10 x 38mm, 10A	2
F3-4	HPS67-821	Fuse, 10 x 38mm, 0.5A	2
F5	HPS67-822	Fuse, 10 x 38mm, 2A	1
	HPS67-807	Fuse Holder	1
T1	HPS67-808	Transformer, 230-400-24V 40VA	1
eb1	HPS67-823	Thermal Overload, 7-11A (Saw Motor)	1
eb2	HPS67-824	Thermal Overload, 1.4-2A (Scoring Motor)	1
C1,C2	HPS67-825	Capacitor, 40uF	2
AU1	HPS67-811	Emergency Stop Frame	1
AU2	HPS67-812	Emergency Stop Electrical Cabinet	1
SE1	HPS67-813	Micro Switch Saw Cover	1
S1	HPS67-826	Start Switch, 1Ph (Saw Motor)	1
S2	HPS67-815	Start Switch, 1Ph (Scoring Motor)	1
KM1	HPS67-817	Magnetic Starter (3.7kw 230V AB-C12) Saw Motor	1
KM2	HPS67-818	Magnetic Starter (.55kw 230V AB-C12) Scoring Motor	1

Electrical Connections – 3 Phase

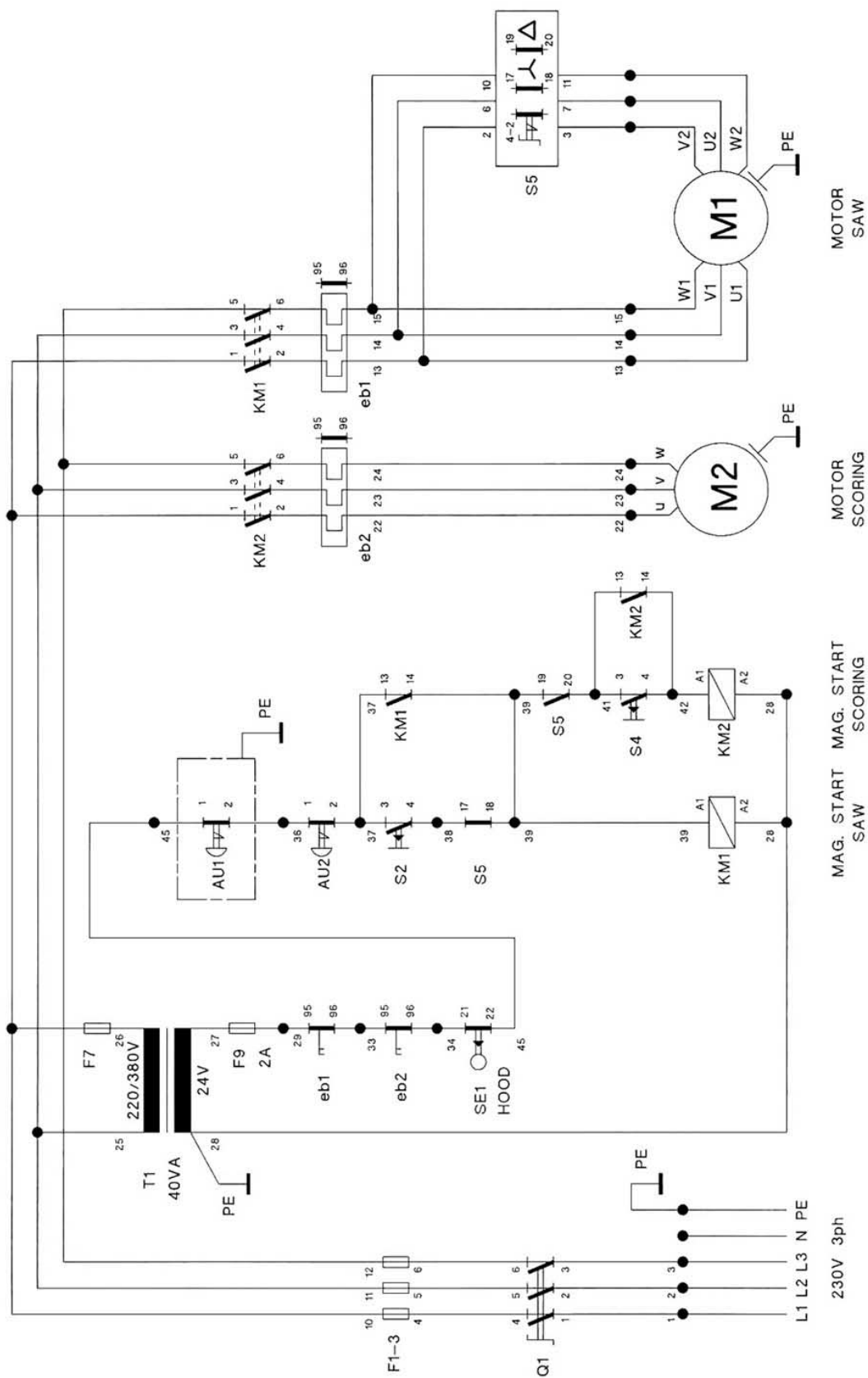

HPS67 POWERMATIC MANUAL 

Electrical Connections – 1 Phase

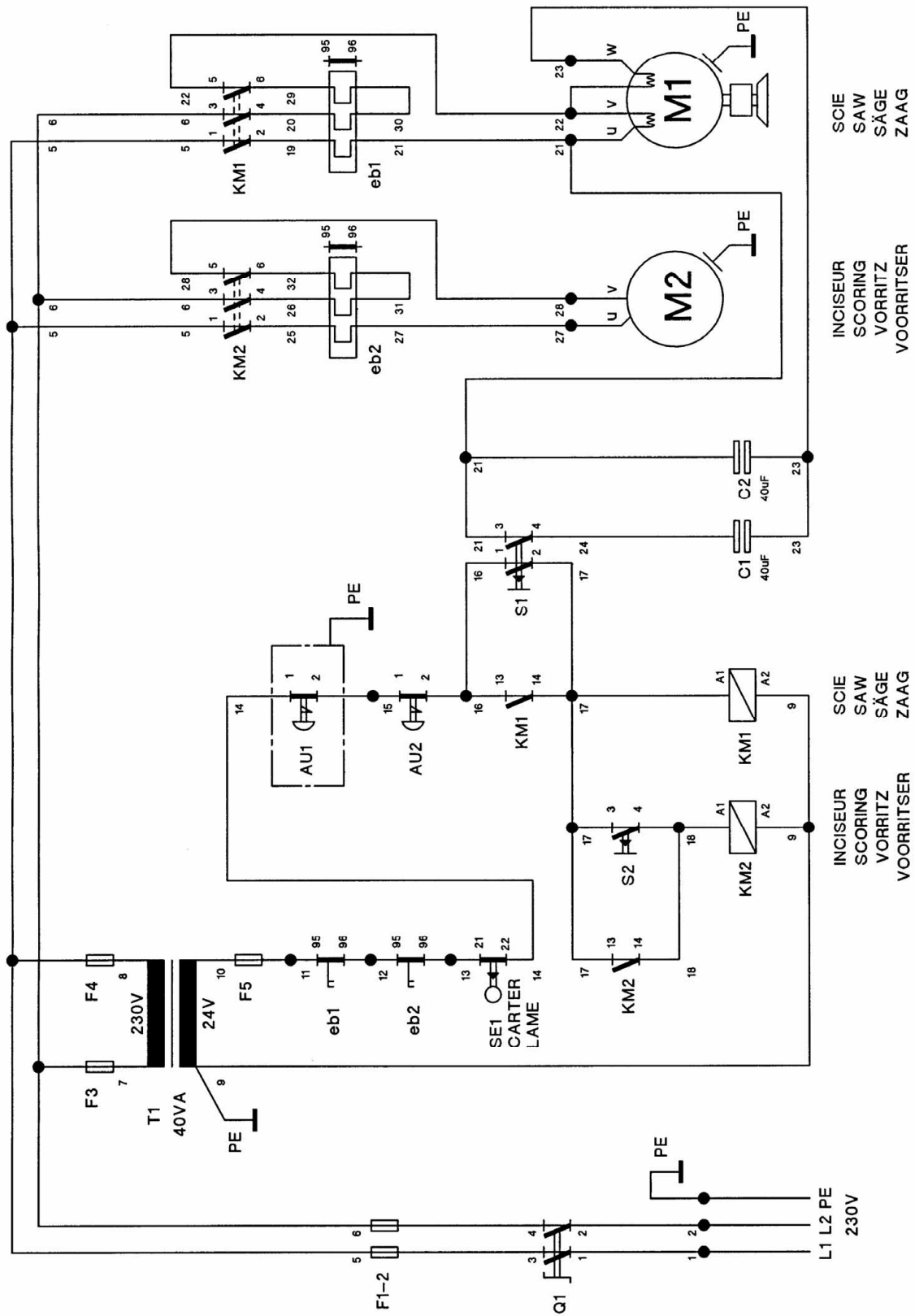

HPS67 Single Phase

NOTES

POWERMATIC[®]

WMH Tool Group
2420 Vantage Drive
Elgin, Illinois 60124
Phone: 800-274-6848
www.wmhtoolgroup.com